

# Kansas Agricultural Experiment Station Research Reports

---

Volume 0  
Issue 2 *Dairy Research (1984-2014)*

Article 389

---

2006

## Dairy Research 2006

Kansas Agricultural Experiment Station

Follow this and additional works at: <https://newprairiepress.org/kaesrr>

---

### Recommended Citation

Kansas Agricultural Experiment Station (2006) "Dairy Research 2006," *Kansas Agricultural Experiment Station Research Reports*: Vol. 0: Iss. 2. <https://doi.org/10.4148/2378-5977.7166>

This report is brought to you for free and open access by New Prairie Press. It has been accepted for inclusion in Kansas Agricultural Experiment Station Research Reports by an authorized administrator of New Prairie Press. Copyright 2006 the Author(s). Contents of this publication may be freely reproduced for educational purposes. All other rights reserved. Brand names appearing in this publication are for product identification purposes only. No endorsement is intended, nor is criticism implied of similar products not mentioned. K-State Research and Extension is an equal opportunity provider and employer.



# DAIRY RESEARCH 2006



## Report of Progress 965

*Dairy Research 2006*

**CONTENTS**

<b><u>Nutrition and Feeding</u></b> .....	<b>Page</b>
Effects of Four Soybean Meal Products on Lactational Performance of Dairy Cows .....	1
Evaluation of Ruminant Degradability and Lysine Bioavailability of Four Soybean Meal Products .....	6
Efficiency of Phosphorus Utilization in Dairy Operations .....	12
<b><u>Reproduction</u></b>	
Responses of Lactating Holstein Cows to Increasing Amounts of Wet Corn Gluten Feed .....	14
Delaying Injection of Prostaglandin F <sub>2α</sub> in an Ovsynch Protocol .....	18
Resynchronization of Ovulation and Conception in Nonpregnant Dairy Cows and Heifers .....	22
Ovarian Responses, Conception Rates, and Pregnancy Survival in Response to GnRH, hCG, and Progesterone .....	26
Ovulation Potential of Human Chorionic Gonadotropin Versus GnRH .....	32
<b><u>Dairy Foods</u></b>	
Milk Quality as a Function of Temperature-cycled, Reduced-fat Milk Stored in Various Size Containers .....	34
<b><u>Facilities and Heat Abatement</u></b>	
Evaluate the Efficacy of “Heat Stress Audits” of Your Cooling System through Core Body Temperature .....	38
Consumptive Water Usage of Evaporative Pads .....	44
Characteristics of Low-profile Cross-ventilated Freestalls .....	49
Influence of Facilities on Cow Time Budgets .....	52
Index of Key Words .....	56
Acknowledgments .....	57
Biological Variability and Chances of Error .....	58
The Livestock and Meat Industry Council .....	59



## **Introducing Dr. Barry Bradford .....**



With the retirement of Dr. John Shirley in 2005, we had the opportunity to recruit a new faculty member. We are pleased that Dr. Bradford has joined our faculty as ruminant nutritionist, with emphasis in dairy cattle. Barry joined the faculty in the Department of Animal Sciences and Industry at K-State with a 60% research-40% teaching appointment. He will be teaching Dairy Cattle Nutrition and also lecture in other courses, in addition to conducting research.

Barry was raised on a cow-calf operation in southwest Iowa and was involved in 4-H and FFA programs throughout his youth. While completing a B.S. at Iowa State University, he worked with Dr. Don Beitz studying the causes of fatty liver in early lactation dairy cattle. Barry then began a Ph.D. program with Dr. Mike Allen at Michigan State University, where his research focused on metabolic regulation of feed intake in dairy cattle. After completing his graduate work in September 2006, Barry relocated to Manhattan with his wife, Sarah, and their daughter, Hannah.



*Dairy Research 2006*

## **EFFECTS OF FOUR SOYBEAN MEAL PRODUCTS ON LACTATIONAL PERFORMANCE OF DAIRY COWS**

*M. S. Awawdeh, E. C. Titgemeyer, J. S. Drouillard, and J. E. Shirley*

### **Summary**

Thirty-two multiparous Holstein cows (152 days in milk, producing 90 lb/day of milk at the beginning of the study) were used in a 4 × 4 Latin square design with 28-day periods to investigate cow responsiveness to supplemental ruminally undegraded protein from 4 soybean meal products. The 4 products were: solvent soybean meal (SSBM), expeller soybean meal (ESBM), lignosulfonate-treated soybean meal (LSBM), and SSBM treated with 0.05% baker's yeast and toasted at 212°F (YSBM). Diets were formulated by substituting all SSBM and part of ground corn with YSBM, ESBM, or LSBM to yield isonitrogenous diets. Diets were formulated to provide adequate ruminally degraded protein, but deficient ruminally undegraded protein and metabolizable protein supplies. No differences among dietary treatments were observed for dry matter intake, body weight gain, milk and component yields, or efficiency of milk production. Lack of response to changes in soybean meal source was likely because of adequate ruminally undegraded protein and metabolizable protein supply by all diets.

(Key Words: Protein, Soybean Meal.)

### **Introduction**

Metabolizable protein requirements of dairy cows are met by microbial protein and by dietary protein that escapes the rumen. In early lactation, microbial protein is not able to support milk production in high-producing dairy cows. Thus, supply of ruminally unde-

graded protein may be warranted. Soybean meal is a commonly used supplemental plant protein in the United States and is characterized by high palatability and well-balanced and available essential amino acid contents. Extensive ruminal degradability limits the utilization of soybean meal by ruminants as a source of ruminally undegraded protein. Various methods have been used to treat soybean meal to alter its ruminal degradability and thereby increase its escape protein content, but "overprotection" can impair protein quality of soybean meal by altering the nutritional availability of amino acids, particularly availability of lysine. Our objective was to compare the effects of four soybean meal products on performance of lactating dairy cows.

### **Procedures**

We evaluated the effects of 4 soybean meal products on performance of lactating dairy cows. The four products were: solvent soybean meal (SSBM), expeller soybean meal (ESBM), lignosulfonate-treated soybean meal (LSBM), and SSBM treated with 0.05% baker's yeast and steeped for 10 minutes at 86°F before toasting at 212°F (YSBM).

Thirty-two multiparous Holstein cows averaging 152 ± 63 days in milk, 1560 ± 170 lb of body weight, and 90 ± 15 lb/day of milk at the beginning of the study were assigned to 1 of 4 free-stall pens in a 4 × 4 Latin square. The lactation number of cows ranged between 2 and 7, averaging 3.1. The experimental units were pens of 8 cows. The 4 diets (Table

1) were formulated to be isonitrogenous by substituting all SSBM and part of the ground corn with YSBM, ESBM, or LSBM. The SSBM diet was formulated to supply adequate amounts of ruminally degraded protein, but deficient amounts of ruminally undegraded protein and, consequently, to be deficient in metabolizable protein supply. Also, diets were formulated to be more limited by lysine supply than by methionine supply by adding methionine from MetaSmart (Adisseo, Alpharetta, GA) to all diets. This was to investigate the responsiveness of cows to ruminally undegraded protein and lysine supplies from the soybean meal products. Cows were injected throughout the study with recombinant bST (Posilac; Monsanto, St. Louis, MO) at 14-day intervals. Each period was 28 days, with a 14-day adaptation; only data from the last 14 days of each period were used for statistical analyses.

Diets were fed as total mixed ration and offered twice daily, at 5:00 a.m. and 11:30 a.m. The amount of diet offered and refused was recorded daily for each pen and was adjusted to ensure orts of about 10% of intake and, therefore, to allow for *ad libitum* consumption. Samples of orts were collected daily, and dry matter was measured to determine daily intakes. Samples of corn silage were collected weekly to measure dry matter, and its inclusion in diets was adjusted accordingly. Samples of dietary ingredients were collected weekly, composited by period, and analyzed for nutrient composition.

Cows were milked twice daily, at 7:30 a.m. and 7:30 p.m., and individual milk weights were recorded. Composite milk samples (a.m./p.m.) from individual cows were collected weekly and analyzed by the Heart of America DHI Laboratory (Manhattan, KS). Immediately after the morning milking, cows were weighed and scored for body condition

(1 to 5 scale) at the beginning of the study and at the end of each period.

## Results and Discussion

Diets contained an average of 16.9% crude protein (dry matter basis) and were formulated to be isonitrogenous (Table 1). Nutrient compositions of dietary ingredients were generally similar to expectations. Chemical compositions of the soybean meal products are presented in an accompanying report (see p. 6) and were similar to expectations. Contents of individual amino acids (% of crude protein) in the 4 soybean meals were similar among products, except for lysine, which was greater in SSBM (7.6%) and ESBM (7.6%) than in YSBM (6.2%) or LSBM (6.7%), likely due to the presence of more chemically cross-linked lysine in YSBM and LSBM that would not be measured by our assay.

Effects of dietary treatments on cow performance are presented in Table 2. There were no significant effects of dietary treatments on feed intake, body weight gain, milk and component yields, and efficiency of milk produced. We purposefully formulated the SSBM and ESBM diets to be sufficient in ruminally degraded protein, but deficient in ruminally undegraded protein and, therefore, metabolizable protein supply was designed to be inadequate to support production of 90 lb/day of milk (initial milk production by cows before the start of the trial), according to recommendations of the 2001 National Research Council (NRC) publication *Nutrient Requirements of Dairy Cattle*. The NRC predicted, based on milk production at the beginning of the study (90 lb/d) and the predicted feed intakes (56 lb/day of dry matter), that the SSBM and ESBM diets were deficient in both ruminally undegraded protein supply and metabolizable protein supply. Thus, increasing the supply of ruminally undegraded



protein by replacing SSBM with YSBM or LSBM could improve cow performance. At the end of the study, however, diets were re-evaluated by using the observed feed intakes (average of 60 lb/day of dry matter) and milk production (average of 74 lb/day), and all diets (including SSBM and ESBM) were predicted to be adequate in ruminally undegraded protein and metabolizable protein supply to support the actual amount of milk produced. This might explain the lack of response to changes in ruminally undegraded protein supply. High feed intake by our cows (60 lb/day) may have supported microbial protein supplies to the small intestine, resulting in little need for supplemental ruminally undegraded protein.

In our study, statistical analysis of data from only the cows with greatest milk productions failed to detect differences among treat-

ments, suggesting that the lack of treatment response can not be attributed solely to the modest milk production level of the cows. It is also possible that changing the source of protein did not substantially impact the supply of lysine to the cows because those soybean meal products that provided more ruminally undegraded protein may have contained a greater proportion of lysine that was unavailable to the cows.

In summary, dairy cows producing about 74 lb of milk daily and fed dietary ruminally undegraded protein concentrations of 5.5% of dry matter did not benefit when SSBM was replaced by alternative sources of soybean meal, likely because ruminally undegraded protein supply was adequate in all diets or because the supply of absorbable lysine (the amino acid predicted to be the most limiting in our diets) was not different between diets.

**Table 1. Diet Composition**

Ingredient	Soybean Meal (SBM) Product <sup>1</sup>			
	SSBM	YSBM	ESBM	LSBM
	----- % of dry matter -----			
Alfalfa	30.7	30.7	30.7	30.6
Corn, ground	26.2	26.2	24.8	25.5
Corn silage	16.5	16.5	16.5	16.4
Whole cottonseed	8.9	8.9	8.9	8.8
Soybean meal	6.9	6.8	8.3	7.6
Soybean hulls	6.8	6.8	6.8	6.9
Molasses	1.2	1.2	1.2	1.2
Limestone	1.0	1.0	1.0	1.0
Sodium bicarbonate	0.81	0.81	0.81	0.81
Calcium phosphate	0.34	0.34	0.34	0.34
Trace mineral salt <sup>2</sup>	0.29	0.29	0.29	0.29
Magnesium oxide	0.20	0.20	0.20	0.20
MetaSmart <sup>3</sup>	0.14	0.14	0.14	0.14
Vitamin ADE premix <sup>4</sup>	0.14	0.14	0.14	0.14
Zinpro 4-plex <sup>5</sup>	0.05	0.05	0.05	0.05
Sodium selenite premix <sup>6</sup>	0.01	0.01	0.01	0.01
Nutrient				
Crude protein	16.8	16.8	16.7	17.3
Ruminally degraded protein	11.3	10.4	11.1	10.8
Ruminally undegraded protein	5.5	6.4	5.6	6.5
NDF	32.0	33.1	32.5	31.8
ADF	19.8	19.7	20.0	19.1
Calcium	1.08	1.08	1.09	1.09
Phosphorus	0.40	0.40	0.40	0.40
Sulfur	0.22	0.22	0.22	0.22
	----- Mcal/lb dry matter -----			
NE <sub>L</sub>	0.71	0.71	0.71	0.71
	----- % of metabolizable protein -----			
Methionine	2.14	2.10	2.14	2.11
Lysine	6.51	6.39	6.51	6.41

<sup>1</sup>SSBM = solvent SBM, ESBM = expeller SBM, LSBM = liginosulfonate-treated SBM, and YSBM = SSBM treated with 0.05% baker's yeast and steeped for 10 minutes at 86°F before toasting at 212°F.

<sup>2</sup>Composition: 94% salt, 0.35% zinc, 0.20% iron, 0.20% magnesium, 0.03% copper, 0.007% iodine, and 0.005% cobalt.

<sup>3</sup>Source of methionine (22.2% of weight as metabolizable methionine).

<sup>4</sup>Provided 2,395 IU vitamin A, 1,200 IU vitamin D, and 15 IU vitamin E per pound of diet dry matter.

<sup>5</sup>Provided 13 ppm zinc, 7 ppm manganese, 4.5 ppm copper, and 0.9 ppm cobalt to the diets (dry matter basis).

<sup>6</sup>Provided 0.06 ppm selenium to the diet (dry matter basis).

**Table 2. Effect of Soybean Meal Products on Performance of Dairy Cows**

Item	Soybean Meal (SBM) Product <sup>1</sup>				SEM
	SSBM	YSBM	ESBM	LSBM	
Weight change, lb/28 days	-2	7	11	-6	9.3
BCS change/28 days	0.20	-0.11	0.01	0.01	0.06
Dry matter intake, lb/day	59.3	60.0	60.2	60.8	1.2
Milk, lb/day	72.8	74.1	75.4	74.1	0.8
4% FCM, lb/day	67.9	67.9	69.9	68.6	1.1
ECM, lb/day	73.2	73.4	75.6	74.3	1.1
Milk/dry matter intake	1.22	1.23	1.24	1.22	0.026
FCM/dry matter intake	1.14	1.13	1.15	1.13	0.039
ECM/dry matter intake	1.23	1.23	1.25	1.23	0.040
Milk					
Protein, %	3.12	3.07	3.11	3.11	0.028
Fat, %	3.59	3.48	3.54	3.55	0.070
Lactose, %	4.64	4.68	4.67	4.65	0.026
SNF, %	8.64	8.64	8.71	8.68	0.026
Protein, lb/d	2.23	2.25	2.31	2.28	0.029
Fat, lb/d	2.58	2.55	2.65	2.59	0.064
Lactose, lb/d	3.39	3.47	3.54	3.45	0.037
SNF, lb/d	6.26	6.39	6.55	6.42	0.064
Somatic cell count	586	618	452	705	82
Urea nitrogen, mg/dL	15.0	15.3	15.2	14.5	0.34

<sup>1</sup>SSBM = solvent SBM, ESBM = expeller SBM, LSBM = liginosulfonate-treated SBM, and YSBM = SSBM treated with 0.05% baker's yeast and steeped for 10 minutes at 86°F before toasting at 212°F.

*Dairy Research 2006*

## EVALUATION OF RUMINAL DEGRADABILITY AND LYSINE BIOAVAILABILITY OF FOUR SOYBEAN MEAL PRODUCTS

*M. S. Awawdeh, E. C. Titgemeyer, J. S. Drouillard, and R. S. Beyer*

### Summary

Evaluations of four soybean meal (SBM) products were conducted. The products were: solvent SBM (SSBM), expeller SBM (ESBM), lignosulfonate-treated SBM (LSBM), and SSBM treated with 0.05% Baker's yeast and toasted at 212°F (YSBM). *In situ* ruminal degradations of YSBM and LSBM were slower than those of SSBM or ESBM; thus, ruminally undegraded protein contents of YSBM and LSBM were greater than those of SSBM or ESBM. The ruminally undegraded protein of all SBM products had similar small intestine digestibility when assessed by susceptibility to enzymatic digestion *in vitro*. Available lysine contents, estimated chemically or using standard chick growth assay, were less for YSBM and LSBM than for SSBM or ESBM, suggesting deleterious effects of processing on lysine availability in those products.

(Key Words: Availability, Protein, Soybean Meal.)

### Introduction

Soybean meal (SBM) is a supplemental protein commonly used as a supplement for dairy cattle. Soybean products are characterized by high palatability and well-balanced and available amino acid contents. But extensive ruminal degradability of SBM limits its utilization by ruminants as a source of ruminally undegraded protein. Various methods have been used to treat soybean products to alter their ruminal degradability, and thereby

increase their escape protein content, but "overprotection" can impair protein quality of SBM by altering the nutritional availability of amino acids, particularly that of lysine. This study was conducted to compare the ruminal degradability, intestinal digestibility, and lysine bioavailability of 4 SBM products.

### Procedures

We evaluated the ruminal degradability, intestinal digestibility, and lysine bioavailability of solvent SBM (SSBM), expeller SBM (ESBM), lignosulfonate-treated SBM (LSBM), and SSBM treated with 0.05% Baker's yeast (*Saccharomyces cerevisiae*) and steeped for 10 minutes at 86°F before toasting at 212°F (YSBM; Table 1). The SSBM and YSBM were from the same source, but ESBM and LSBM were commercial products.

***In Situ Protein Degradability.*** Two ruminally cannulated Jersey steers fed a typical dairy diet were used. To estimate *in situ* protein degradability, 1.5 to 2.0 grams of ground samples of the 4 SBM products were weighed in duplicate for each incubation time (0, 2, 4, 8, 16, 24, and 48 hours) into polyester bags, which were heat-sealed, presoaked in cold tap water, and placed into the ventral sac of the rumen at different time points. Bags were then simultaneously removed from the rumen and washed with cold water in a commercial washing machine with 1 minute of delicate agitation and 2 minutes of spin per rinse for 5 cycles. Bags were then dried and analyzed for residual nitrogen content.

Protein fractions (A, B, and C) and degradation rate of fraction B ( $k_B$ ) were estimated by using the model:

$$\text{Residual nitrogen} = (B \times e^{-(k_B \times t)}) + C$$

where B is the slowly degraded protein fraction, C is the completely undegradable protein fraction, t is incubation time, and  $k_B$  is the degradation rate of fraction B. Fraction A, the instantly degraded protein fraction, was calculated by difference,  $A = 1 - B - C$ .

***Intestinal Digestibility of Ruminally Undegraded Protein.*** Digestibility of ruminally undegraded protein was determined by a 3-step procedure. Samples were incubated in the rumen of fistulated steers for 16 hours. Residues in the bags after ruminal incubation were then subjected to digestion with pepsin and pancreatin *in vitro*. Intestinally digestible protein was calculated as that solubilized by the enzymes. Digestible protein in the SBM products was calculated as ruminally undegraded protein content multiplied by the intestinal digestibility of the ruminally undegraded protein.

***Lysine Bioavailability by Chick Growth Assay.*** Broiler chicks (n = 480, 1-day old) were used in a chick-growth assay to compare the relative bioavailability of lysine in the 4 SBM products. Chicks were housed in temperature-regulated starter batteries, in 48 pens with 10 chicks per pen. Birds had free access to feed and water. At the conclusion of the study (9 days), each pen of birds was weighed to calculate weight gains, and unconsumed feed was weighed to allow calculation of feed intake.

Chicks were fed one of 12 diets based on corn and SBM. Four of the treatments, for which data are not presented, were used to verify that performance of chicks in our model was most limited by the supply of lysine. The

SSBM diet contained 26% SSBM, and the remaining treatments were formulated to be isonitrogenous by varying the amount of corn starch added to diets. Treatments included the 4 SBM sources and residuals from the four SBM sources after 12-hours of *in situ* ruminal incubation. We evaluated the *in situ* residues to determine if the ruminal incubation, which would be experienced if the SBM sources were fed to cattle, altered lysine availability.

Ruminal residuals were obtained by using ruminally cannulated steers consuming a typical dairy cow diet. About 200 grams of the SBM sources were weighed into polyester bags, heat-sealed, and placed in the ventral sac of the rumen of a steer. After 12 hours of incubation, bags were removed and washed in cold water, and bag residues were freeze-dried before being used in the chick diets.

***Lysine Availability by Assay of Chemically Available Lysine.*** Available lysine contents of SBM products were estimated by using a chemical availability assay. Chemically available lysine in the original SBM and residues after 12 hours of ruminal incubation were colorimetrically measured according to the 1-fluoro-2, 4-dinitrobenzene procedure. Available lysine is defined as units whose side-chains are free and can react with 1-fluoro-2,4-dinitrobenzene. Lysine units whose side-chains are bound to other groups will not react with 1-fluoro-2,4-dinitrobenzene and are considered to be nutritionally unavailable.

## Results and Discussion

***In Situ Protein Degradability.*** Data for *in situ* CP degradation for the SBM products are presented in Table 2. Although not statistically different, likely due to small number of replications (two per incubation time per steer), differences among SBM products in sizes of the protein fractions and degradation

rates are observable. The YSBM and the LSBM had greater contents of ruminally undegraded protein than did SSBM or ESBM, predominantly as a result of a slower degradation rate ( $k_B$ ) for YSBM and a larger fraction C for LSBM.

Our measured value for ruminally undegraded protein for LSBM (78%) was similar to expectations, whereas that for ESBM (51%) was less than expected and that for SSBM (42%) was greater. Few published values are available to compare with our measure for YSBM (75%).

***Intestinal Digestibility of Ruminally Undegraded Protein.*** Intestinal digestibilities of ruminally undegraded protein from SBM products are presented in Table 3. There were no differences among SBM products for intestinal digestibility of ruminally undegraded protein, which averaged 82%. Because there was more ruminally undegraded protein in YSBM and LSBM than in SSBM and ESBM, the proportions of ingredient protein that were available post-ruminally were greater for YSBM (66%) and LSBM (64%) than for SSBM (39%) or ESBM (48%).

Data from lysine availability studies described in the next section indicate that the lack of differences among SBM sources in intestinal digestion, as evaluated by the 3-step procedure, is not completely correct, at least for lysine availability.

***Lysine Bioavailability by Chick Growth Assay.*** Results of data not shown demonstrated that chick performance was limited by lysine supply and, thus, that our study provided a comparison of the relative lysine bioavailabilities in the SBM products.

When original SBM products were tested (Table 4), SSBM and ESBM resulted in similar chick performance (feed intake, daily gain,

gain:feed), but they yielded better performance than YSBM and LSBM, indicating that lysine was more available for growth in SSBM and ESBM than in YSBM and LSBM. Feeding YSBM resulted in worse performance than feeding LSBM, suggesting that lysine was less available for growth in YSBM than in LSBM. This might be, in part, due to “over protection” of YSBM during processing, which might have led to deleterious effects on lysine availability.

Feeding *in situ* residues of SSBM, ESBM, or LSBM resulted in similar performance (feed intake, daily gains, and feed efficiency), but performance was better than that from feeding *in situ* residues of YSBM. If a prediction of performance was based on total lysine content only (Table 4), it would be expected that feeding *in situ* residues of LSBM would result in worse chick performance than feeding SSBM or ESBM, simply because LSBM (5.8% of CP) had less total lysine content than did SSBM (6.7% of CP) or ESBM (7.0% of CP).

For each SBM product, we tested the original SBM, as well as SBM that was previously incubated *in situ* for 12 hours, to 1) simulate what actually occurred when SBM was fed to cattle and 2) investigate if the comparisons among different SBM products using the original SBM were comparable to those using *in situ* residues. Using *in situ* residues for SSBM or ESBM yielded less feed intake and slower gains, but more efficient gains, compared with using the original SSBM and ESBM. This could be due to depressed feed intake as a result of poor palatability of the *in situ* residues.

In general, using ruminal *in situ* residues or original SBM in the chick growth assay yielded similar ranking of SBM products in terms of lysine availability, except for LSBM, which led to worse performance than SSBM

or ESBM when the original SBM products were compared, but equal performance when the *in situ* residues were compared. It is possible that some of the unavailable lysine in LSBM became available to the chicks after 12 hours of ruminal incubation. Our data indicates that lysine availability in SBM products can be impacted by ruminal incubation.

***Lysine Availability by Assay of Chemically Available Lysine.*** Chemically available lysine (% of crude protein; Table 4) was greater for original SSBM (5.5%) and ESBM (5.3%) than for YSBM (4.1%) or LSBM (4.3%). Chemically available lysine contents (% of crude protein) for *in situ* residues of SSBM (5.2%), ESBM (5.3%), and LSBM (5.1%) were similar to each other (Table 4), but greater than that in YSBM (3.9%), which agrees with chick performance data.

Chemically available lysine contents in the *in situ* residues were almost identical to the original SBM for the same product, except for LSBM. It is possible that some of the unavailable lysine in the original LSBM became available after ruminal incubation, resulting in greater content of available lysine (5.1 vs. 4.3%).

***Conclusions.*** Treating SBM with ligno-sulfonate or yeast, followed by heating to induce non-enzymatic browning, was successful in protecting LSBM and YSBM from ruminal degradation, without affecting their intestinal digestibility as measured by susceptibility to enzymatic digestion. Processing of YSBM and LSBM, however, seemed to decrease lysine bioavailability as measured either by the chick growth assay or by a chemically available lysine procedure.

**Table 1. Nutrient Composition of Soybean Meal Products**

Nutrient	Soybean Meal (SBM) Product <sup>1</sup>			
	SSBM	YSBM	ESBM	LSBM
	----- % of dry matter -----			
Neutral detergent fiber	13.5	31.8	12.9	22.7
Acid detergent fiber	7.6	8.1	8.6	10.5
Ether extract	2.9	2.9	8.0	2.7
Crude protein	55.8	55.9	47.9	51.2
	----- % of crude protein -----			
Arginine	6.8	6.3	7.0	6.3
Histidine	2.6	2.4	2.8	2.6
Isoleucine	5.3	5.5	5.1	5.3
Leucine	7.8	7.6	7.7	7.7
Lysine	7.6	6.2	7.6	6.7
Methionine	0.9	1.1	0.8	1.0
Phenylalanine	5.4	5.3	5.1	5.3
Threonine	3.9	4.0	3.8	3.8
Tyrosine	3.4	3.5	3.1	3.4
Valine	4.9	4.9	5.0	4.8
	----- % of total nitrogen -----			
Neutral detergent insoluble nitrogen	11.5	42.1	8.0	29.0
Acid detergent insoluble nitrogen	5.7	6.4	4.2	9.9

<sup>1</sup>SSBM = solvent SBM, ESBM = expeller SBM, LSBM = lignosulfonate-treated SBM, and YSBM = SSBM treated with 0.05% baker's yeast and steeped for 10 minutes at 86°F before toasting at 212°F.

**Table 2. In Situ Protein Degradation Kinetics of Soybean Meal Products**

Item	Soybean Meal (SBM) Product <sup>1</sup>				SEM
	SSBM	YSBM	ESBM	LSBM	
Fraction, %					
A <sup>2</sup>	21	11	25	7	7
B <sup>3</sup>	78	89	70	61	22
C <sup>4</sup>	0	0	4	31	18
K <sub>B</sub> , %/hour <sup>5</sup>	3.8	1.1	2.6	2.0	0.9
Ruminally undegraded protein, % <sup>6</sup>	42 <sup>b</sup>	75 <sup>a</sup>	51 <sup>b</sup>	78 <sup>a</sup>	2.1

<sup>1</sup>SSBM = solvent SBM, ESBM = expeller SBM, LSBM = lignosulfonate-treated SBM, and YSBM = SSBM treated with 0.05% baker's yeast and steeped for 10 minutes at 86°F before toasting at 212°F.

<sup>2</sup>Instantly degraded N.

<sup>3</sup>Slowly degraded protein fraction.

<sup>4</sup>Completely undegradable protein fraction.

<sup>5</sup>Degradation rate of fraction B.

<sup>6</sup>Estimated using the fractions and rate for each SBM for an incubation time of 16 hours.

<sup>a, b</sup> Values having different superscript letters within row differ ( $P < 0.05$ ).



**Table 3. Intestinal Digestibility of Ruminally Undegraded Protein of Soybean Meal Products**

Item	Soybean Meal (SBM) Product <sup>1</sup>				SEM
	SSBM	YSBM	ESBM	LSBM	
Ruminally undegraded protein, % <sup>2</sup>	48 <sup>c</sup>	83 <sup>a</sup>	55 <sup>b</sup>	81 <sup>a</sup>	1.5
Intestinal digestibility, % of ruminally undegraded protein	82	80	86	78	2.0
Intestinal availability, % of ingredient crude protein <sup>3</sup>	39 <sup>c</sup>	66 <sup>a</sup>	48 <sup>b</sup>	64 <sup>a</sup>	1.9

<sup>1</sup>SSBM = solvent SBM, ESBM = expeller SBM, LSBM = lignosulfonate-treated SBM, and YSBM = SSBM treated with 0.05% baker's yeast and steeped for 10 minutes at 86°F before toasting at 212°F.

<sup>2</sup>Ruminally undegradable protein on the basis of 16-hour *in situ* ruminal incubation.

<sup>3</sup>Ruminally undegraded protein × intestinal digestibility.

<sup>a, b, c</sup>Values having different superscript letters within row differ,  $P \leq 0.05$ .

**Table 4. Total and Chemically Available Lysine and Performance of Chicks Fed Original Soybean Meal Products or *In Situ* Residues of Soybean Meal Products<sup>1</sup>**

Item	Original Soybean Meal (SBM) Product				SEM
	SSBM	YSBM	ESBM	LSBM	
Total lysine in SBM, % of crude protein	7.6	6.2	7.6	6.7	
Chemically available lysine in SBM, % of crude protein	5.5	4.1	5.3	4.3	
Dry matter intake, grams/day	18.3 <sup>a</sup>	11.4 <sup>c</sup>	17.9 <sup>a</sup>	15.1 <sup>b</sup>	0.40
Daily gain, grams/day	14.8 <sup>a</sup>	7.9 <sup>c</sup>	14.6 <sup>a</sup>	11.5 <sup>b</sup>	0.34
Gain:Feed	0.81 <sup>a</sup>	0.70 <sup>c</sup>	0.81 <sup>a</sup>	0.76 <sup>b</sup>	0.01
	12-h <i>In Situ</i> Residue of SBM Product				
	SSBM	YSBM	ESBM	LSBM	
Total lysine in SBM, % of crude protein	6.7	4.9	7.0	5.8	
Chemically available lysine in SBM, % of crude protein	5.2	3.9	5.3	5.1	
Dry matter intake, grams/day	14.72 <sup>a,z</sup>	10.68 <sup>b</sup>	15.04 <sup>a,z</sup>	14.56 <sup>a</sup>	0.40
Daily gain, grams/day	12.53 <sup>a,z</sup>	7.60 <sup>b</sup>	12.95 <sup>a,z</sup>	12.23 <sup>a</sup>	0.34
Gain:Feed	0.852 <sup>a,z</sup>	0.711 <sup>b</sup>	0.861 <sup>a,z</sup>	0.840 <sup>a,z</sup>	0.01

<sup>1</sup>SSBM = solvent SBM, ESBM = expeller SBM, LSBM = lignosulfonate-treated SBM, and YSBM = SSBM treated with 0.05% baker's yeast and steeped for 10 minutes at 86°F before toasting at 212°F. The SSBM diet contained 26% SSBM, and the other diets were formulated to be isonitrogenous by removing all of the SSBM, adding an isonitrogenous amount of the alternative SBM, and adjusting the amount of corn starch.

<sup>a, b, c</sup>Values having different superscript letters within row differ ( $P < 0.05$ ).

<sup>z</sup>Values differ from original of the same SBM product ( $P < 0.05$ ).

*Dairy Research 2006*

## **EFFICIENCY OF PHOSPHORUS UTILIZATION IN DAIRY OPERATIONS**

*M. J. Brouk and J. P. Harner<sup>1</sup>*

### **Summary**

Efficient utilization of nutrients is a must on modern dairies. Most of the phosphorus arriving at the dairy will either be found in purchased feedstuffs or commercial fertilizer used to raise grain and forage for the dairy. In general, those dairies that purchase all feeds are more efficient with phosphorus utilization than those that grow forage and grain. This is likely due to increased inefficiencies associated with feeding and crop enterprises. Careful evaluation of diets to reduce feeding excess phosphorus can reduce phosphorus excretion in the manure by as much as 50%. This not only reduces input costs, but also reduces the total cost of land application. The most efficient way to manage dairy farm nutrients is to develop a comprehensive nutrient management plan that includes both the cropping and animal enterprises. This plan will help producers predict phosphorus requirements of cattle and crops, and then allow the producer to control phosphorus inputs to meet the requirements.

(Key Words: Nutrient Management, Phosphorus.)

### **Introduction**

Phosphorus utilization has become a concern for Kansas dairy producers, and is a key factor in whole-farm nutrient management.

Whole-farm nutrient management allows producers to evaluate phosphorus utilization across the entire farm, including both animal and crop utilization. Research in the past 10 years has indicated that it is possible to improve the efficiency of phosphorus utilization by dairies. This reduces phosphorus imports and exports via manure. Reducing phosphorus exports via manure could potentially reduce the area required for manure land application. In addition, more efficient application of manure and reduction of phosphorus excretion through increased feeding efficiency will reduce the cost of phosphorus inputs, increasing the total farm profitability. This paper will explore the sources of phosphorus found on the dairy farm, export of phosphorus from the dairy, and the impacts of reducing phosphorus imports to the dairy.

### **Phosphorus Imports**

Phosphorus is imported onto the farm in 4 major areas; feed, fertilizer, animals, and bedding. One important distinction between farms is the presence or absence of a cropping enterprise. Dairies that do not raise crops will generally import more than 95% of the total phosphorus in feedstuffs. These dairies import both concentrates and forages. Bedding and animals would account for the remaining amount. Dairies that have cropping enterprises will import about 55 to 65% of the phosphorus in purchased feeds and approxi-

---

<sup>1</sup>Department of Biological and Agricultural Engineering.

mately 33 to 42% in commercial fertilizer. When feeding a mix of corn silage and legumes, approximately 25% of the total phosphorus is associated with the forages, and the remaining 75% is associated with the concentrate supplements. Careful management of dietary phosphorus in animal diets and fertilizer application is key for minimizing phosphorus imports onto the dairy farm.

### **Phosphorus Exports**

Phosphorus is exported from the farm in animal products, manure, and cash crops. Animal products, including animal sales and milk, account for about 55 to 75% of the total phosphorus exports. Farms that do not have a cropping enterprise will have greater exports because manure will be distributed to other farms for land application. Efficiency of phosphorus utilization is a key factor in reducing the build-up of phosphorus on commercial dairy farms.

### **Phosphorus Balance**

Several studies conducted during the last decade have shown that most dairies import more phosphorus than is necessary for efficient dairy production. When surveyed, many dairies typically feed diets that contain 0.4 to 0.5% phosphorus on a DM basis. Based on the rates of milk production and normal DM intakes, dietary phosphorus should be 0.35 to 0.38%. Thus, many dairies are feeding 20 to 25% more phosphorus than is needed for efficient milk production. This excess phosphorus will be excreted in the manure, increasing the land mass necessary for manure disposal. Farms that have cropping enterprises have been shown to import excess phosphorus in the form of fertilizer. This, combined with excess phosphorus in the feed, generally makes these units more inefficient in phosphorus utilization than dairies without cropping enterprises. As greater amounts of corn processing co-products (distillers grains and corn

gluten feed) are used in dairy diets, there is a potential that amounts of dietary phosphorus may increase. These products generally contain high concentrations of phosphorus, and this must be taken into account when balancing rations. When using high concentrations of corn co-products, it may not be possible to keep the dietary phosphorus below 40%. Phosphorus content of these feedstuffs may become the limiting factor in determining the maximum amount included in diets.

On the cropping side, many dairy producers have been land-applying manure for a few generations. Applying manure year after year will likely result in phosphorus build-up in the soils. This is much more common when crop removal has been exceeded by land application of manure. This problem is much more common in those fields that are closest to the dairy. It is difficult to resist the temptation to dispose of manure on the fields near the dairy.

### **Comprehensive Nutrient Management**

Because of the variation in soil phosphorus concentrations found on many dairy farms, dairy farms should develop a comprehensive nutrient management plan that is not limited to just phosphorus. Developing a plan will increase total farm nutrient utilization and, over time, may reduce nutrient concentrations in soils that exceed recommended levels. The key to a successful plan is to first determine the true phosphorus needs of both the animals and, if included, the cropping operation. The next step is to track the nutrient flowing into and out of the dairy. Efficient use of phosphorus in animal diets will reduce phosphorus excretion in the manure. Reductions in phosphorus concentration in the manure reduce the land area required for efficient land application. When cropping enterprises are included, balancing soil levels, crop removal rates, and manure application will ensure that phosphorus does not continue to accumulate in the soil.

*Dairy Research 2006*

## RESPONSES OF LACTATING HOLSTEIN COWS TO INCREASING AMOUNTS OF WET CORN GLUTEN FEED

*M. J. Brouk, J. F. Smith, and K. Grigsby<sup>1</sup>*

### Summary

Forty lactating Holstein cows were allocated into groups of 5 cows each and assigned to 8 pens containing 10 freestalls each. Each group contained 3 heifers and 2 multiparous cows. Groups were balanced by milk production and days in milk. Diets were formulated to contain none (control), 12, 24, or 36% wet corn gluten feed (WCGF) on a dry matter (DM) basis. Increasing amounts of WCGF and heat-treated expeller soybean meal replaced a portion of the corn silage, alfalfa hay, corn grain, soybean meal, and soybean hulls of the control diet to maintain similar concentrations of crude protein (CP), ruminally undegraded crude protein (RUP), and neutral detergent fiber (NDF). A Latin Square design with 4-week periods was used. Periods were 4 weeks in duration, with 2 weeks of adjustment followed by 2 weeks of data collection. Milk weights were recorded at each milking, and weekly milk samples (a.m. and p.m.) were collected for milk component analysis. Milk and feed data were averaged by pen and week before analysis. Milk production, energy-corrected milk production, and efficiency of energy-corrected milk production increased with increasing amounts of WCGF. Dry matter intake was unaffected by diet. These data indicate that WCGF can be utilized effectively at 36% of the ration DM if concentrations of RUP, CP, and NDF are maintained in the diet.

(Key Words: By-products, Nutrition, Wet Corn Milling.)

### Introduction

Increased ethanol and corn sugar production have greatly increased the availability of corn processing co-products. One of the co-products of the wet milling process is wet corn gluten feed (WCGF). It is readily available in the Midwest and can be easily incorporated into dairy cattle diets. Wet corn gluten feed is an excellent source of ruminally fermentable fiber and crude protein. It can be used to replace a portion of the forage and crude protein supplements of lactating dairy cattle diets. The objective of this experiment was to determine the impact of increasing amounts of WCGF on the performance of lactating Holstein dairy cattle.

### Procedures

Forty lactating cows, averaging 155 days in milk and producing an average of 112 lb of milk daily, were allocated into groups of 5 cows each and were assigned to 1 of 8 pens containing 10 freestalls each. Each group contained 3 heifers and 2 multiparous cows. Groups were balanced by milk production and stage of lactation. Diets containing none (control), 12, 24, or 36% WCGF on a dry matter (DM) basis were formulated to contain similar concentrations of crude protein (CP), ruminally undegraded crude protein (RUP),

---

<sup>1</sup>Cargill, Inc., Blair, NE.

and neutral detergent fiber (NDF). This was achieved by replacing a portion of the corn silage, alfalfa hay, corn grain, soybean meal, and soyhulls in the control diet with WCGF (SweetBran, Cargill, Inc., Blair, NE) and heat-treated expeller soybean meal. Ingredients and nutrient composition of diets are in Table 1. Cows were fed a TMR twice daily, and amounts fed and refused were recorded daily by pen. Cows were milked twice daily, and milk yield was recorded. Milk samples (a.m. and p.m.) were collected once weekly for composition analysis. Milk composition was then calculated, based on the actual percentages of the a.m. and p.m. milking during which samples were collected. Before data analysis, all results were averaged by pen, period, and week within period. Feed samples of individual diet ingredients were collected weekly and composited by period before analysis. Diet nutrients were then calculated from individual diet ingredients.

## Results and Discussion

Diets provided adequate amount of nutrients to meet or exceed NRC requirements (Table 1). Amounts of CP were greater than anticipated because of greater than expected concentrations in the diet ingredients. Dry matter intake was unaffected by treatment. Addition of WCGF to the diet reduced the DM content of the TMR. Cows fed 36% WCGF produced more ( $P<0.05$ ) milk (Table 2) than cows fed the other diets. Linear increases in milk production were observed when feeding diets containing 12 to 36% WCGF. These results indicate that milk production was still increasing at the 36% DM

rate. Therefore, feeding greater concentrations of WCGF may be beneficial. Feeding only 12% WCGF did not offer any advantage over the control diet.

Milk fat percentage was unaffected by treatment, but milk fat production increased ( $P<0.05$ ) with increasing amounts of WCGF. Milk protein percentage increased with increasing amounts of WCGF. Cows fed the 24 or 36% diets had greater ( $P<0.05$ ) concentrations of milk protein and milk protein production than did controls. Energy corrected milk production and efficiency of ECM production also increased ( $P<0.05$ ) with increasing amounts of WCGF. Occurrence of increased milk, protein, and fat production with increasing amounts of WCGF, without a change in DM intake, might indicate that total diet digestibility was increased when WCGF replaced diet ingredients that were possibly less digestible than WCGF. Adding WCGF to the diet also increased the amount of soluble CP in the rumen. More soluble CP may have increased rumen fermentation, resulting in a more complete fermentation of the diet and increased energy and bacterial protein becoming available to the cows.

These data show that milk, protein, fat, and ECM increased when WCGF was fed at 24 to 36% of DM. In addition, efficiency of milk production was improved. Data suggest that more than 12% WCGF is required to increase milk, protein, and fat production. Additional studies are warranted to determine the optimum amount of WCGF that could be fed to lactating dairy cows.

**Table 1. Ingredients and Nutrient Composition of Diets**

Item	Diet <sup>1</sup>			
	0%	12%	24%	36%
Ingredient	-----% of dry matter (DM)-----			
Alfalfa hay	24.54	24.70	21.26	18.14
Corn silage	23.06	23.22	20.10	17.07
Corn grain	23.88	20.37	17.60	15.11
WCGF <sup>2</sup>	-	11.36	22.97	34.05
Whole cottonseed	8.43	8.48	8.57	8.62
Solvent soybean meal	8.68	4.98	2.21	...
Soybean hulls	5.08	...	...	...
Expeller soybean meal	3.33	3.82	4.06	3.71
Limestone	1.02	1.10	1.29	1.41
Sodium bicarbonate	0.82	0.82	0.82	0.83
Trace mineralized salt <sup>3</sup>	0.37	0.37	0.37	0.37
Magnesium oxide	0.27	0.24	0.21	0.17
Vitamin ADE premix <sup>4</sup>	0.02	0.02	0.02	0.02
Vitamin E premix <sup>5</sup>	0.02	0.02	0.02	0.02
Sodium selenite premix <sup>6</sup>	0.01	0.01	0.01	0.01
4-Plex <sup>7</sup>	0.06	0.06	0.06	0.06
Molasses	0.41	0.41	0.41	0.41
Nutrient				
DM, %	65.20	61.91	60.91	60.04
Crude protein, %	18.45	18.36	18.67	18.90
ADF, %	21.53	21.03	20.22	19.14
NDF, %	33.62	34.25	35.01	35.38
NE <sub>L</sub> , Mcal/lb	0.75	0.76	0.77	0.77
Calcium, %	1.15	1.04	1.04	0.99
Phosphorus, %	0.33	0.41	0.49	0.56
Magnesium, %	0.39	0.37	0.38	0.37
Potassium, %	1.46	1.52	1.49	1.49

<sup>1</sup>0%=0% WCGF, 12%=12% WCGF, 24%=24% WCGF, 36%=36% WCGF (DM basis).

<sup>2</sup>WCGF=Wet corn gluten feed (SweetBran, Cargill Nutrition).

<sup>3</sup>Composition: not less than 95.5%NaCl, 0.24% Mn., 0.24% Fe, 0.05% Mg, 0.032% Cu, 0.032% Zn, 0.007% I, 0.004% Co.

<sup>4</sup>Contributed 5,750 IU vitamin A, 2,875 IU vitamin D, 17 IU vitamin E per kg of diet DM.

<sup>5</sup>Provided 23 IU vitamin E per kg of diet DM.

<sup>6</sup>Provided 0.06 mg Se per kg of diet DM.

<sup>7</sup>Zinpro corporation.

**Table 2. Effects of Diets on Performance of Lactating Cows**

Item	Diet <sup>1</sup>				SEM
	0%	12%	24%	36%	
DM intake, lb/day	56.8	56.2	57.3	57.4	0.92
Milk, lb/d	80.7 <sup>a</sup>	82.8 <sup>ab</sup>	85.5 <sup>b</sup>	89.3 <sup>c</sup>	1.42
Milk fat, %	3.58	3.54	3.73	3.67	0.08
Milk protein, %	2.96 <sup>a</sup>	2.96 <sup>ab</sup>	2.98 <sup>b</sup>	3.02 <sup>b</sup>	0.02
Milk MUN, mg/dL	17.0	16.3	16.5	17.0	0.35
Milk fat, lb/day	2.88 <sup>a</sup>	2.93 <sup>b</sup>	3.15 <sup>c</sup>	3.29 <sup>c</sup>	0.08
Milk protein, lb/day	2.37 <sup>a</sup>	2.44 <sup>b</sup>	2.54 <sup>b</sup>	2.68 <sup>b</sup>	0.09
ECM <sup>2</sup> , lb/day	80.8 <sup>a</sup>	82.5 <sup>a</sup>	87.06 <sup>b</sup>	91.08 <sup>c</sup>	1.62
ECM/DM intake	1.42 <sup>a</sup>	1.47 <sup>ab</sup>	1.52 <sup>b</sup>	1.60 <sup>c</sup>	0.03

<sup>1</sup>0%=0% WCGF, 12%=12% WCGF, 24%=24% WCGF, 36%=36% WCGF (DM basis).

<sup>2</sup>Energy corrected milk.

## DELAYING INJECTION OF PROSTAGLANDIN F<sub>2α</sub> IN AN OVSYNCH PROTOCOL

*J. S. Stevenson, M. A. Portaluppi, and D. E. Tenhouse*

### Summary

Our objective was to determine whether delaying the PGF<sub>2α</sub> injection by 24 or 48 hr after the first GnRH injection in an Ovsynch protocol (from a standard 7 days) altered ovarian characteristics in lactating dairy cows. Estrous cycles were synchronized in 36 Holsteins after removal of a progesterone-releasing controlled internal drug release (CIDR) insert and injection of PGF<sub>2α</sub>. On day 6 of the estrous cycle, cows were administered 100 µg of GnRH (81 ± 2 days postpartum) and assigned randomly to receive a treatment injection of PGF<sub>2α</sub> 7, 8, or 9 days later. Timed artificial insemination (TAI) was performed at 48 hr after PGF<sub>2α</sub>, at which time a second injection of GnRH was administered. Ovarian structures were mapped by ultrasonography on day 0 (first GnRH injection), on day 2 to determine responses to the first GnRH injection, at PGF<sub>2α</sub> injection, and daily thereafter through 72 hr after PGF<sub>2α</sub> to monitor ovulation of preovulatory follicles. Blood was collected on day 0, day 2, at PGF<sub>2α</sub> injection, and at 24 and 48 hr after PGF<sub>2α</sub>, to monitor serum changes estradiol-17β and progesterone. On the basis of serum progesterone and ovarian exams, 2 cows were eliminated because of anestrus and their failure ovulate a follicle in response to the first GnRH injection. Two other cows in which luteolysis failed to occur after PGF<sub>2α</sub> treatment also were eliminated. Final numbers of cows per treatment were: 7 days (n = 13), 8 days (n = 9), and 9 days (n = 10). Twenty-nine of 32 cows ovulated (90.6%) in response to the first GnRH injection.

Despite a 24- or 48-hr delay between first GnRH and PGF<sub>2α</sub> injections, the diameter (mm) and volume (mm<sup>3</sup>) of the ovulatory follicle did not differ among treatments. In all 32 cows, at least 1 follicle ovulated after treatment, but ovulation rates did not differ. Serum concentrations of estradiol-17β did not differ among treatments. Two cows in the 7-day treatment and 2 cows in the 8-day treatment were inseminated 24 hr late and were excluded before assessing conception rates: 5/9 (55.6%), 5/9 (55.6%), and 1/10 (10%), respectively. We concluded that delaying PGF<sub>2α</sub> injection by 24 hr had little effect on outcomes.

(Key Words: Follicle, Ovsynch, Ovulation, Pregnancy Rate.)

### Introduction

Before advent of the Ovsynch protocol [injection of GnRH 7 days before and 48 hr after an injection of PGF<sub>2α</sub>, with one timed AI (TAI) at 12 to 16 hr after the second GnRH injection], 33% of all dairy operations were using some type of programmed breeding system that used prostaglandin F<sub>2α</sub> (PGF<sub>2α</sub>) to synchronize estrus, with rates of use greater for operations with 200 or more cows (50.2%) than for those with 100 to 199 cows (45%) or less than 100 cows (31.1%). Since then, timed AI (TAI) protocols likely have become even more popular among dairy producers, and are used in nearly 10% of all U.S. dairy herds.

Development of synchronized ovulation was based on earlier reports in which a new



follicular wave was initiated in response to an injection of GnRH 6 to 7 days before PGF<sub>2α</sub> injection. Emergence of a new follicular wave in response to GnRH led to greater homogeneity of ovarian follicular inventories among cows at the time of induced luteolysis. Improved synchrony of estrus resulting from coordinated follicular maturation and luteal regression (after administering GnRH 7 days before PGF<sub>2α</sub>) was first demonstrated in dairy heifers, and later in lactating dairy cattle.

Once a new dominant follicle is selected, concentrations of estradiol-17β increase, LH pulses increase, and the selected dominant follicle becomes the preovulatory follicle. Maximum concentrations of estradiol-17β in serum preceding ovulation, however, are 30% less in lactating dairy cows than in heifers, even though ovulatory follicles are 13% larger in diameter. Further, maximum concentrations of progesterone are 30% less in cows than in heifers, despite cows having 53% more luteal tissue. Discrepancies between sizes of ovarian structures and serum steroid concentrations may result from greater rates of steroid metabolism in lactating dairy cows than in heifers and among cows of various milk-producing abilities.

Reduced serum steroid concentrations may have numerous potential physiologic consequences that compromise fertility in lactating cows. We hypothesized that greater concentration of serum estradiol-17β in lactating cows may occur when using the Ovsynch protocol if PGF<sub>2α</sub>-induced luteolysis is delayed after the first GnRH injection. Our objective was to determine whether lengthening the interval between the first GnRH injection and PGF<sub>2α</sub> from 7 to 8 or 9 days might result in greater serum concentrations of estradiol-17β and larger follicles, possibly leading to increased fertility after AI.

## Procedures

The experiment was conducted at the Kansas State University Dairy Teaching and Research Center, with 36 lactating Holstein cows that calved between August and September 2004 and had an average body condition score =  $2.3 \pm 0.1$ . Daily test-day milk yield of these cows nearest to the day of first AI averaged  $109 \pm 4$  lb (3.5% fat and 3.0% protein) and 305-d mature equivalent yield averaged  $33,854 \pm 946$  lb. Cows were housed in covered free stalls bedded with sand, and were fed a TMR 3 times daily.

Beginning at  $65 \pm 2$  days postpartum, estrous cycles were synchronized in lactating dairy cows (average body weight =  $1,559 \pm 26$  lb) by applying a progesterone-releasing controlled internal drug release (CIDR) insert (Eazi-Breed CIDR, Pfizer Animal Health, New York, NY) for 7 days, plus 25 mg of PGF<sub>2α</sub> (Lutalyse, Pfizer Animal Health, New York, NY) given 24 hr before CIDR insert removal. Nine days after CIDR insert removal (approximately day 6 of the estrous cycle), cows received 100 μg of GnRH (Cystorelin, Merial Limited, Iselin, NJ) and then were allocated randomly to 1 of 3 treatments in which they received 25 mg of PGF<sub>2α</sub> at days 7, 8, or 9 after the first GnRH injection (day 0 was  $81 \pm 2$  days postpartum).

Inseminations were administered at 48 hr after PGF<sub>2α</sub> ( $91 \pm 2$  postpartum), at which time the second 100-μg injection of GnRH was administered. Pregnancy was diagnosed, 32 to 34 days after TAI, by using transrectal ultrasonography. A positive diagnosis included confirmation of a CL, uterine fluid, and an embryonic heart beat.

Ultrasonography was conducted on days 0 and 2, and daily thereafter, beginning with

PGF<sub>2α</sub> treatment and continuing through 72 hr after PGF<sub>2α</sub>, to monitor ovarian structures. Ovarian follicles were mapped and sized on days 0 and 2 to determine responses to the first GnRH injection. In subsequent scans, all follicles were mapped and sized to monitor the dominant ovarian follicle that developed after the first GnRH injection, and that later became the preovulatory follicle.

Blood samples were collected from a coccygeal vessel on days 0 and 2; daily thereafter, beginning with PGF<sub>2α</sub> treatment and continuing through 72 hr after PGF<sub>2α</sub>; on day 14; and on day 21. The samples were stored on ice, and serum concentrations of progesterone and estradiol-17β were later quantified by radioimmunoassay.

## Results and Discussion

Changes in average diameter of the largest (putative dominant) follicle that subsequently ovulated, monitored after the first GnRH injection, are illustrated in Figure 1. Small differences were detected among treatments in the diameter of the largest follicle from days 2 to 10. Cows in the 9-day treatment had slightly smaller ( $P < 0.05$ ) follicle diameters on days 2 to 9. Average diameter or average volume of the resulting preovulatory follicles, however, assessed at 72 hr after PGF<sub>2α</sub>, did not differ among treatments (Table 1). When diameters and volumes (not shown) of the preovulatory follicles were standardized to the day when PGF<sub>2α</sub> treatment was administered, no differences were detected among treatments. At least 1 follicle ovulated per cow (range of 1 to 2), and ovulation rates did not differ among treatments (Table 1).

When serum concentrations of estradiol-17β (not shown) were expressed relative to days since PGF<sub>2α</sub> treatment, no differences were evident among treatments. Patterns of luteal regression, as assessed by decreasing

concentrations of progesterone at 24 and 48 hr after PGF<sub>2α</sub> (not shown), were not different when expressed relative to day of PGF<sub>2α</sub> treatment injection. All 32 cows subsequently ovulated and formed new CL (Table 1) after treatment, as is further evidenced by increased concentrations of progesterone in serum at 14 and 21 days after the first GnRH injection (not shown).

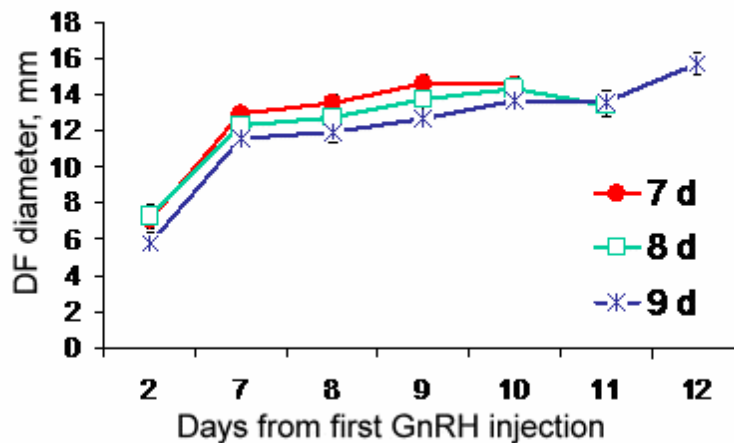
Two cows each in the 7- and 8-day treatments were inseminated 24 hr late (not according to protocol). Of the remaining cows in each of these 2 treatments, 5 of 9 cows (55.6%) conceived in the 7-day treatment, and 5 of 9 cows (55.6%) conceived in the 8-day treatment, compared with only 1 of 10 cows (10%) in the 9-day treatment. Conception rates of individual 7- and 8-day treatments tended ( $P = 0.07$ ) to differ from that of the 9-day treatment. Two of the 4 cows (50%) that failed to ovulate after the first GnRH injection conceived, whereas 9 of 24 cows (37.5%) conceived that ovulated at least 1 follicle after the first GnRH injection. Although too few cows were inseminated to test differences in conception rates, reproductive outcomes may not be reduced when PGF<sub>2α</sub> injection is delayed by 24 hr from the standard 7-day period between GnRH and PGF<sub>2α</sub> injections, but 48 hr may be too long to prevent a potentially reduced conception rate.

In conclusion, prolonging the lifespan of a newly recruited dominant follicle in the presence of a functional CL by 24 to 48 hr, from the standard 7-day interval between the first GnRH injection of the Ovsynch protocol and the injection of PGF<sub>2α</sub>, failed to increase serum concentrations of estradiol-17β or diameter of that dominant follicle. Further study is warranted to verify whether delaying PGF<sub>2α</sub> injections by 24 h has no effects on fertility and whether PGF<sub>2α</sub> injections may be given late (d 8), when not given at d 7 as planned.

**Table 1. Largest Diameter and Volume of Preovulatory Follicles that Ovulated After Treatment in Response to the Second GnRH Injection, and Resulting Ovulation Rate**

Item <sup>1</sup>	Interval Between First GnRH Injection and PGF <sub>2α</sub> , days		
	7	8	9
Diameter of largest follicle, mm	14.3 ± 0.6	14.1 ± 0.8	15.3 ± 0.9
Volume of largest follicle, mm <sup>3</sup>	1526 ± 62	1479 ± 97	1490 ± 69
Ovulation rate	1.2 ± 0.1	1.1 ± 0.1	1.3 ± 0.2

<sup>1</sup>Assessed 72 hr after PGF<sub>2α</sub> in each treatment.



**Figure 1. Changes in Average Diameter of the Dominant Follicle that Eventually Ovulated After Each of 3 Treatments in Which PGF<sub>2α</sub> was Administered Either 7 Days (n = 13), 8 Days (n = 9), or 9 Days (n = 10) After the First GnRH Injection (d 0).**

*Dairy Research 2006*

## RESYNCHRONIZATION OF OVULATION AND CONCEPTION IN NONPREGNANT DAIRY COWS AND HEIFERS

*J. S. Stevenson, M A. Portaluppi, and D. E. Tenhouse*

### Summary

Our objectives were to determine various factors influencing upfront single and multiple ovulation in response to GnRH in a timed artificial insemination (TAI) protocol and subsequent fertility after altering timing of the second GnRH injection and AI relative to PGF<sub>2α</sub> injection. Replacement heifers (n = 86) and 613 lactating cows previously inseminated were diagnosed not pregnant at biweekly intervals to form 77 breeding clusters spanning 36 months. At not-pregnant diagnosis (day 0), females received 100 µg of GnRH, and they received 25 mg of PGF<sub>2α</sub> 7 days later. Females in 2 treatments received GnRH 48 hr (G48) after PGF<sub>2α</sub> injection and TAI at the time of the second GnRH injection (G48 + TAI48) or 24 hr later (G48 + TAI72). Females in the third treatment received GnRH 72 hr after PGF<sub>2α</sub>, when inseminated (G72 + TAI72). Ovaries of females in 65 clusters were scanned at day 0 (first GnRH injection) and 7 days later (PGF<sub>2α</sub> injection). Ovarian structures were mapped, and ovulation in response to the first GnRH injection was detected on day 7. When estrus was detected before scheduled TAI, females were inseminated; otherwise TAI conception of remaining females was based on timing of GnRH and AI in 3 treatments. On day 7, 1 or more luteal structures (CL) were detected in 46% of females. Conception rate was 26.5% (98/701) in females that showed estrus and were inseminated early. Pregnancy rate was greater in females that ovulated after the first GnRH injection (day 0) and during nonsummer months. Compared with females in late diestrus at

nonpregnant diagnosis, cows in early diestrus or those with functional cysts had greater pregnancy rates, but rates were not different from those of cows in proestrus or in metestrus or anestrus. Pregnancy rates did not differ among treatments, but a tendency was detected for a treatment × lactation number interaction. In heifers and first-lactation cows, the G72 + TAI72 treatment produced fewer pregnancies, whereas G48 + TAI48 treatment was least efficacious in older cows. In a TAI protocol for previously inseminated dairy females that are diagnosed not pregnant, subsequent timed AI pregnancy rates are greater when females are in early diestrus, ovulate in response to the first GnRH injection, or both.

(Key Words: Luteolysis, Ovsynch, Ovulation, Pregnancy Rate.)

### Introduction

Several factors are known to influence fertility after a timed AI (TAI) in dairy cattle when ovulation is synchronized with a GnRH injection followed in 7 days by PGF<sub>2α</sub> in an Ovsynch-like protocol (GnRH injection given 7 days before and 48 hr after luteolysis is induced by PGF<sub>2α</sub>). Day of the estrous cycle at the onset of such protocols influenced incidence of ovulation and follicle diameter after the first leading GnRH injection and the second ovulatory GnRH injection that followed PGF<sub>2α</sub>-induced luteolysis. Cows treated between days 1 and 4 had the smallest incidence of ovulation (23%), followed by those between days 10 and 16 (54%), days 17 to 21 (77%), and days 5 to 9 (96%). Further, diame-

ter of the ovarian follicle that ovulated in response to the first GnRH injection was smaller for cows on days 1 to 4 and 17 to 21 than on days 5 to 16. Cows early (d 1 to 4) and late (days 17 to 21) in the estrous cycle at the first GnRH injection had larger-diameter ovulatory follicles than those injected on days 5 to 13, whereas pregnancy rates were greatest for cows in which the Ovsynch protocol was initiated between days 5 and 14 (42%) and less for those injected on days 1 to 4 and 14 to 21 (32%). Thus, follicle size at the onset of the Ovsynch protocol seems to be important to predispose a maximum ovulatory response to GnRH. Little is known about ovulatory responses to GnRH differing based on ovarian follicular populations, luteal status, season, and lactation status.

Timing of the GnRH and AI influence TAI pregnancy rates. When GnRH was administered at 48 hr after the PGF<sub>2α</sub> injection of the Ovsynch protocol, and cows were inseminated at 48, 56, 64, 72, or 80 hr after PGF<sub>2α</sub>, pregnancy rates at first service were maximal at 64 hr or 16 hr after GnRH. In lactating dairy cows inseminated after 2 presynchronizing injections of PGF<sub>2α</sub> given 14 days apart (Presynch) and initiating the Ovsynch protocol 12 days after the second Presynch injection, various times of GnRH and TAI were tested. Those cows given GnRH at 48 hr after the PGF<sub>2α</sub> injection of Ovsynch and inseminated at that time (48 hr after PGF<sub>2α</sub>) or 24 hr later (Cosynch 48) had lesser pregnancy rates than those of cows injected and inseminated at 72 hr after PGF<sub>2α</sub> (Cosynch 72).

The obvious advantage of such treatments is the convenience of carrying out all hormonal injections and TAI at the same time of the day, when cows are conveniently restrained by feed-line lockups. In recent studies, similar treatments initiated 11 days after Presynch (Cosynch 48 and Cosynch 72) produced lesser pregnancy rates in dairy cows, compared with

administering GnRH at 56 hr after PGF<sub>2α</sub> and inseminating cows 16 hr later. These results also were consistent in that study for cows in which the Ovsynch protocol was applied with the same treatments after a not-pregnant diagnosis.

The objective of our study was to examine various factors that influence the leading, first GnRH-induced ovulatory response and resulting pregnancy rates in conjunction with altered timing of the second GnRH injection and TAI.

### Procedures

Dairy females (replacement heifers and lactating cows) previously inseminated were diagnosed nonpregnant at biweekly intervals. At the nonpregnant diagnosis, females were blocked by lactation number (0, 1, or 2+) and assigned randomly to 3 treatments consisting of variations of the Ovsynch protocol (Figure 1). Cows in 2 treatments received injections of GnRH 7 d before, and 48 hr (G48) after the PGF<sub>2α</sub> injection. Timed AI was conducted at the time of the second GnRH injection (G48 + TAI48) or 24 hr later (G48 + TAI72). Cows in the third treatment received the injections of GnRH 7 days before, and at 72 hr after PGF<sub>2α</sub>, and were inseminated at the time of the second GnRH injection (G72 + TAI72). When estrus was detected before projected TAI, females were inseminated, based on symptoms of estrus, according to the a.m.-p.m. rule.

Ultrasonography was conducted to monitor ovarian structures in the first 65 of the 77 clusters of females assigned to treatments (584 of 699 females). Ovarian follicles were mapped and sized (all follicles ≥ 5 mm were measured) on day 0. Numbers of follicles and luteal structures were quantified per ovary. On day 7, occurrence of ovulation of any follicle was recorded in response to the first GnRH injection given on day 0.

## Results and Discussion

Incidence of ovulation in response to the first GnRH injection averaged 46%. It tended ( $P = 0.07$ ) to differ in magnitude among different days of the estrous cycle (range = 36.5 to 58.3%). Replacement heifers had the smallest incidence of ovulation (29.2%). As lactation number increased from 0 to 3 or more, ovulation incidence increased ( $P < 0.001$ ) linearly.

Timed AI pregnancy rates among females that were scanned, regardless of whether they ovulated in response to GnRH, was not influenced by treatment, days of the estrous cycle, luteal status, lactation number, or number of CL at the time of the first GnRH injection (not shown). Pattern of pregnancy rates over days of the estrous cycle was fitted to a fifth-order polynomial curve ( $P < 0.05$ ), and tended to parallel the pattern of ovulation incidence (not shown).

Pregnancy rate tended ( $P = 0.075$ ) to decrease linearly as the number of follicles  $\geq 8$  mm in diameter increased. Females that ovulated in response to the first GnRH injection had subsequently greater ( $P < 0.05$ ) pregnancy rates than those of females that did not ovulate (32.1 vs. 20.2%). When incidence of ovulation was replaced by the number of ovulations (0, 1, 2 or more), pregnancy rates were 20.0% ( $n = 276$ ), 31.0% ( $n = 176$ ), and 38.5% ( $n = 32$ ), respectively. No difference in pregnancy rate was detected among those females that ovulated 1 vs. 2 or more follicles before timed AI.

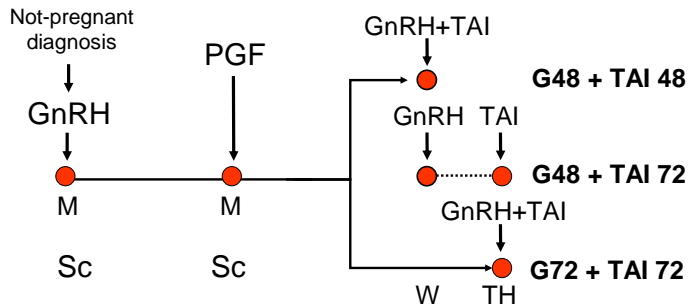
Pregnancy rates in females that were diagnosed as cystic (39.3%;  $n = 17$ ) and in early diestrus (28.7%;  $n = 264$ ) were greater ( $P < 0.05$ ) than in females in late diestrus (11.5;

$n = 78$ ), whereas fertility in anestrous females (19.5%;  $n = 16$ ) and those in proestrus or metestrus (23.5%;  $n = 152$ ) did not differ from either of the preceding cycling status categories. As expected, pregnancy rates were reduced ( $P < 0.05$ ) during summer, compared with other seasons.

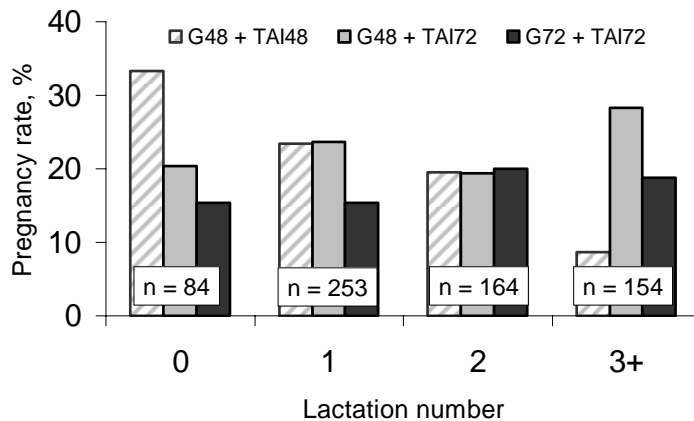
Pregnancy rates in dairy females that ovulated were affected by the total number of follicles  $\geq 8$  mm in diameter and by season. As number of total follicles decreased, pregnancy rates decreased ( $P < 0.001$ ) linearly. Pregnancy rates also were reduced ( $P < 0.05$ ) during summer for cows that ovulated.

Pregnancy rates did not differ among treatments, but a strong tendency ( $P = 0.09$ ) was detected for an interaction between treatment and lactation number (Figure 2). In heifers and first-lactation cows, the G72 + TAI72 produced fewer pregnancies, whereas the G48 + TAI48 was least efficacious in older (3+) cows. Females initiating the Ovsynch protocol in early diestrus (22.8%;  $n = 336$ ), proestrus or metestrus (22.5%;  $n = 207$ ), or having a cystic functional structure (27.4%;  $n = 17$ ) had greater ( $P < 0.05$ ) pregnancy rates than those of anestrous females (5.7%;  $n = 22$ ) or those in late diestrus (8.6%;  $n = 103$ ).

In summary, in heifers and first-lactation cows, the G72 + TAI72 treatment produced fewer pregnancies, whereas G48 + TAI48 treatment was least efficacious in older cows. In a TAI protocol for previously inseminated dairy females that are diagnosed not pregnant, subsequent timed AI pregnancy rates are greater when females are in early diestrus or ovulate in response to the first GnRH injection.



**Figure 1. Experimental Design of Treatments.** Nonpregnant heifers and lactating cows were injected with GnRH upon not-pregnant diagnosis and then 7 d later were injected with  $\text{PGF}_{2\alpha}$ . Cows were injected with GnRH at 48 h after  $\text{PGF}_{2\alpha}$  (G48) and inseminated at 48 (TAI48) or 72 h (TAI72) after  $\text{PGF}_{2\alpha}$  or injected with GnRH at 72 h (G72) at the same time as timed AI (TAI72). M = Monday, W = Wednesday, TH = Thursday, SC = ovarian scans by transrectal ultrasonography, GnRH or G = gonadotropin-releasing hormone,  $\text{PGF}$  =  $\text{PGF}_{2\alpha}$ , and TAI = timed AI.



**Figure 2. Interaction of Treatment  $\times$  Lactation Number for Timed AI (TAI) Pregnancy Rate in Dairy cattle.** Depending on the model, the interaction  $P$  values varied between 0.09 and 0.12. Nonpregnant females were injected with GnRH upon not-pregnant diagnosis and then 7 d later were injected with  $\text{PGF}_{2\alpha}$ . Cows were injected with GnRH at 48 h after  $\text{PGF}_{2\alpha}$  (G48) and inseminated at 48 (TAI48) or 72 h (TAI72) after  $\text{PGF}_{2\alpha}$  or injected with GnRH at 72 h (G72) at the same time as timed AI (TAI72).

*Dairy Research 2006*

## **OVARIAN RESPONSES AND CONCEPTION RATES IN RESPONSE TO GnRH, hCG, AND PROGESTERONE<sup>1</sup>**

*J. S. Stevenson, M. A. Portaluppi, D. E. Tenhouse, A. Lloyd,  
D. R. Eborn, S. Kacuba<sup>2</sup> and J. M. DeJarnette<sup>2</sup>*

### **Summary**

We hypothesized that increasing concentrations of progesterone after artificial insemination (AI) would increase fertility. Our objective was to assess changes in ovarian structures, incidence of ovulation, and change in serum progesterone in response to GnRH, human chorionic gonadotropin (hCG), or exogenous progesterone (controlled internal drug release; CIDR insert) treatment, beginning 4 to 9 days after AI (d 0) and again 7 days later (Exp. 1). Blood was collected from 753 cows in 3 herds on days 0 and 7. Ovaries of 162 cows in 1 herd were scanned and mapped to confirm the presence a corpus luteum (CL), and cows were assigned randomly to serve as control (n = 41) or to receive a CIDR insert for 7 days (n = 41), 100 µg of GnRH (n = 40), or 3,300 IU of hCG (n = 40). More cows were induced to ovulate in response to GnRH (60%) and hCG (78%), compared with control (2.4%). Compared with control, cows treated with GnRH or hCG had more induced CL (d 7) and more total CL (d 7), but serum progesterone was increased only in response to hCG. Volume of the original

luteal structures was increased by hCG, but tended to be reduced by CIDR and GnRH, compared with luteal volume in control. Total CL volume was increased by hCG, but reduced by CIDR, compared with CL volume of control. In Exp. 2, cows in 5 herds were used to assess conception rates in response to the same treatments described in Exp. 1: control (n = 708), CIDR (n = 711), GnRH (n = 719), and hCG (n = 714). Tendencies for interactions of treatment × herd and treatment × lactation group were detected, but no 3-way interactions were found. Treatment with hCG increased conception rates in second-lactation cows. The CIDR tended to increase, and hCG increased, conception rates in 2 herds, whereas the CIDR decreased conception rates in 1 herd. We concluded that GnRH and hCG effectively induced ovulation, and increased number of CL, but only hCG increased serum progesterone. Further, treatment with the CIDR or hCG increased conception rates, but only in some herds.

(Key Words: CIDR, GnRH, hCG, Pregnancy Rate.)

---

<sup>1</sup>Select Sires, Waupon, WI, and Plain City, OH, respectively.

<sup>2</sup>We express appreciation to owners and employees at Ohlde's Dairy (Linn, KS), Meier's Dairy (Palmer, KS), Linn Willow Creek Dairy (Linn, KS), and York's Dairy (Cuba City, WI), as well as the staff at our Dairy Teaching and Research Center, for their willingness to cooperate in this study. We acknowledge the financial support for these studies provided by the National Association of Animal Breeders, Columbia, MO.



## Introduction

Conception failure is coincident with less-than-normal concentrations of progesterone as early as day 6 after insemination. In general, blood concentrations of progesterone rise earlier and achieve greater concentrations in pregnant, than in nonpregnant, cows. Embryo development is associated with concentrations of progesterone and the ability of the conceptus to secrete the antiluteolytic hormone, interferon-tau. Exogenous progesterone has been shown to stimulate embryo development. A number of treatments could be employed to increase peripheral concentrations of progesterone after AI, including those that increase endogenous function of the existing corpus luteum (CL), induce accessory CL, or supplement progesterin or progesterone directly.

Human chorionic gonadotropin (hCG) has activity similar to LH, is able to bind to tissue LH receptors, and mimics effects of LH by causing small luteal cells to increase progesterone synthesis. Administration of hCG increases the incidence of ovulation and accessory CL formation. In addition, luteal phase treatment with hCG after AI increased conception rates in some studies.

Inducing accessory CL with GnRH or its agonists is well documented and forms the basis for the first GnRH injection of the Ovsynch protocol. Other research has demonstrated that incidence of ovulation was greatest when GnRH was injected between days 5 and 12 of the estrous cycle.

Studies that administered exogenous progestins during the luteal phase after AI by applying a progesterone-releasing intravaginal device (PRID) for 7 days produced inconsistent effects on conception rates. No increase in conception rates was detected when intravaginal controlled internal drug

release (CIDR) inserts were applied mid-cycle or later. In contrast, when treatments were initiated before midcycle, conception rates were improved for cows treated with CIDR inserts for 6 or 12 days, beginning 4 to 9 days after AI, compared with control (Macmillan and Peterson, 1993). The treatment that most consistently improved conception rates in that study was a 6- or 12-d CIDR insert beginning on 6 to 8 days after AI.

We hypothesized that increasing or supplementing endogenous concentrations of progesterone in lactating dairy cattle early after AI may spare embryonic loss and improve overall conception rates. Our overall objective was to investigate the effect of supplemental blood progesterone and exogenous GnRH and hCG on follicular development, incidence of ovulation, serum progesterone, and conception rate.

## Procedures

Lactating Holstein cows were blocked by days in milk and lactation number (1 vs. 2+) and assigned randomly to 1 of 4 treatments: 1) insert a new CIDR (Eazi-Breed CIDR insert containing 1.38 g of progesterone; Pfizer Animal Health, New York, NY) for 7 days, beginning between 4 and 9 days after AI; 2) 3,300 IU of hCG, i.m. (Chorulon; Intervet, Millsboro, NJ) once between 4 and 9 days after AI; 3) 100 µg of GnRH, i.m. (Fertagyl; Intervet) once between days 4 and 9 after AI; and 4) untreated control. Body condition scores (1 = thin and 5 = fat) were assigned at treatment.

**Experiment 1.** The purpose of Exp. 1 was to assess ovarian responses to GnRH, hCG, and exogenous progesterone (CIDR insert). Ovaries of 162 lactating Holstein cows housed at the Kansas State University Dairy Teaching and Research Center were scanned by using transrectal ultrasonography. Ovarian

structures were mapped and sized on the day of treatment and 7 days later to determine the incidence of ovulation in response to treatment.

Blood was collected at the initiation of treatments and 7 days later to measure treatment effects on serum concentrations of progesterone. Cows located in the Kansas State University dairy, and at 2 commercial dairy farms in which Exp. 2 was conducted, had blood samples collected as described relative to treatments. Blood serum concentrations of progesterone were determined by radioimmunoassay.

**Experiment 2.** The purpose of Exp. 2 was to assess effects of treatments on conception. A total of 2,852 lactating Holstein cows were treated in the Kansas State University herd and at 4 commercial dairy locations (3 herds in Kansas and 1 herd in Wisconsin). Pregnancy was diagnosed by using either transrectal ultrasonography or transrectal palpation, and pregnancy was reconfirmed in all pregnant cows at 14 to 30 days. Conception rates were calculated based on the number of pregnant cows at each diagnosis divided by the number of cows previously inseminated and treated.

## Results and Discussion

Retention of CIDR inserts during 7 days was 94.5% of 752 cows treated with CIDR inserts. Only 711 cows in which the CIDR was retained according to protocol were included in analyses. Cows were treated after AI, which included those occurring at 1 fixed time (timed AI; TAI), after visual detection of estrus, or in response to rubbed tail chalk, activity tags, and other miscellaneous signs of estrus. All cows were inseminated postpartum (first AI after calving) after presynchronization of estrous cycles (Presynch) and synchronization of ovulation (Ovsynch). In cows diagnosed not pregnant,

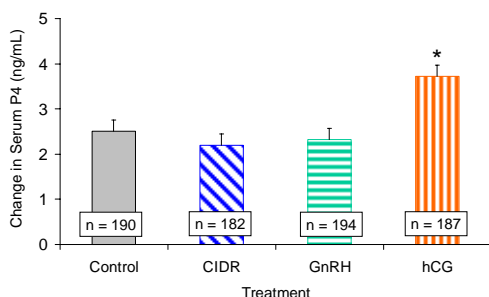
ovulation was resynchronized by using Ovsynch. More than 80% of inseminations that preceded treatments in both experiments were by TAI.

**Experiment 1.** Ovarian characteristics of 162 treated cows are summarized in Table 1. Because a large percentage of the cows eligible for treatment at 4 to 9 days after AI were previously TAI, only cows that had a CL consistent in size for that stage of the estrous cycle or pregnancy at the first ultrasound exam were included in Exp. 1. Mean diameter, just before treatment, of follicles that eventually ovulated in response to either GnRH or hCG did not differ ( $13.8 \pm 0.5$  vs.  $12.7 \pm 0.4$  mm). More ( $P < 0.01$ ) cows treated with GnRH and hCG ovulated at least 1 follicle than did control cows. When only cows having at least 1 follicle  $\geq 10$  mm in diameter at treatment were considered, percentage of follicles that ovulated increased to 64.1% and 81.3% for GnRH and hCG cows, respectively (Table 1). Number of induced CL per cow and total CL per cow 7 days after treatment were greater ( $P < 0.01$ ) in cows treated with GnRH and hCG than in control cows (Table 1).

As expected, original CL increased in diameter and volume during 7 days after treatment in all cows, but increases in diameter ( $P = 0.07$ ) and volume ( $P < 0.05$ ) tended to be, or were, greater for cows treated with hCG than for control cows. In contrast, change in volume of original CL after 7 days in cows from CIDR and GnRH treatments tended ( $P = 0.07$ ) to be less than in control cows. As a consequence, total luteal volume 7 days after treatment was less ( $P < 0.01$ ) in CIDR treatment, but greater in hCG treatment, compared with control (Table 1).

Concentrations of progesterone in serum at the time of treatment and 7 days later were determined in 753 cows in 3 herds. As

expected, average concentration of progesterone in blood serum increased ( $P < 0.001$ ) from day of treatment (4 to 9 days after AI;  $3.2 \pm 0.1$  ng/mL) until 7 days later. Increase in serum progesterone from treatment to 7 days later, however, was greater ( $P < 0.001$ ) in cows treated with hCG than in control cows (Figure 1).



**Figure 1. Change in Concentrations of Progesterone in Serum Between Day of Treatment and 7 Days Later for Cows in Exp. 1.** \*Different ( $P < 0.001$ ) from control.

**Experiment 2.** Conception rates of 2,852 cows in 5 herds described in Tables 2 and 3 were assessed by ultrasonography in 2 herds (herds 1 and 3) and by palpation per rectum of uterine contents in 3 herds (herds 2, 4, and 5). Tendencies were detected for interactions of treatment  $\times$  herd ( $P = 0.11$ ) and treatment  $\times$  lactation group ( $P = 0.07$ ), but no 3-way interactions were detected. Treatment with the CIDR tended to ( $P < 0.10$ ) increase, or increased ( $P < 0.01$ ), conception rates in herds 1 and 3, whereas the CIDR decreased ( $P < 0.05$ ) conception rate in herd 4, compared with rates in the control herd (Table 3). Treatment with hCG increased ( $P < 0.05$ ) conception rates in herd 3. Treatment with

hCG increased ( $P < 0.05$ ) conception rates in second-lactation cows (Table 4). Overall, a priori contrasts indicated that the CIDR tended ( $P = 0.075$ ) to increase and hCG increased ( $P < 0.05$ ) conception rates, compared with control (Table 3).

Conception rates were influenced by herd; rates were greater ( $P < 0.05$ ) in 2 herds (herd 1 = 38.9% and herd 3 = 36.6%) in which pregnancy was diagnosed earlier after AI, compared with the 3 herds in which pregnancy was determined later by palpation (herd 2 = 30.9%, herd 4 = 29.3%, and herd 5 = 23.9%). Month of treatment ( $P < 0.05$ ), days in milk ( $P < 0.001$ ), body condition score ( $P < 0.001$ ), and number of days after AI when treatment was initiated ( $P < 0.05$ ) influenced conception rates, whereas most recent test-day milk yield had no effect. Average day effects across herds indicated that conception rates increased when treatment occurred after day 6 (day 4 = 26.6%, day 5 = 27.6%, day 6 = 26.2%, day 7 = 34.1%, day 8 = 32.5%, and day 9 = 44.5%; no treatment  $\times$  day interaction). Conception rates in response to treatments, based on day after AI when treatment was initiated, are illustrated in Figure 1.

Treatment of lactating dairy cows once with GnRH and hCG between 4 and 9 days after AI effectively induced ovulation, and increased number of CL (not total CL volume after GnRH), but only increased serum P4 in hCG-treated cows. Further, treatment with the CIDR tended to increase, and treatment with hCG increased, conception rates, but only in some herds. Treatment of second-lactation cows with hCG increased conception rates. Further work is warranted to determine how and when vaginally applied progesterone via the CIDR may influence conception rates.

**Table 1. Ovarian Characteristics Before (day 0) and After (day 7) Post-insemination Treatments of Progesterone (CIDR insert), GnRH, and hCG in Lactating Dairy Cows (Exp. 1)**

Trait	Treatment <sup>1</sup>			
	Control	CIDR	GnRH	hCG
Cows, no.	41	41	40	40
	Mean ± SE (n) or % (n)			
Induced ovulation				
% of cows	2.4 (41)	4.9 (41)	60.0** (40)	77.5** (40)
% of follicles	2.9 (34)	5.6 (36)	64.1** (25)	81.3** (37)
Induced CL, (day 7)	0.1 ± 0.1 (41)	0.1 ± 0.1 (41)	0.7 ± 0.1** (40)	1.1 ± 0.1** (40)
Total CL (day 7)	1.6 ± 0.1 (41)	1.3 ± 0.1 (41)	2.0 ± 0.1* (40)	2.4 ± 0.1** (40)
Change in diameter of original CL <sup>2</sup> , mm	3.1 ± 0.7 (55)	2.4 ± 0.7 (50)	1.6 ± 0.7 (50)	4.7 ± 0.7† (52)
Change in volume of original CL <sup>2</sup> , mm <sup>3</sup>	3,131 ± 619 (55)	1,350 ± 662† (50)	1,446 ± 652† (50)	4,766 ± 640* (52)
Total luteal volume (day 7), mm <sup>3</sup>	12,298 ± 1106 (41)	8,008 ± 1101** (41)	12,373 ± 1117 (41)	18,410 ± 1108** (41)

†Different ( $P = 0.07$ ) from control.

\*Different ( $P < 0.05$ ) from control.

\*\*Different ( $P < 0.01$ ) from control.

<sup>1</sup>Cows were treated once with GnRH, hCG, or a CIDR insert, beginning 4 to 9 days after AI. The CIDR insert was removed 7 days later.

<sup>2</sup>Trait assessed on day 7 minus that on day 0.

**Table 2. Conception Rates by Herd in Response to Post-insemination Treatments of Progesterone (CIDR insert), GnRH, and hCG in Lactating Dairy Cows (Exp. 2)**

Herd	Treatment <sup>1</sup> , % (n)			
	Control	CIDR	GnRH	hCG
1	31.7 (41)	50.1† (40)	32.6 (40)	38.7 (38)
2	26.0 (158)	30.8 (158)	28.6 (159)	34.0 (158)
3	26.9 (143)	40.3** (162)	31.3 (153)	37.8* (153)
4	33.8 (206)	23.4* (204)	29.8 (209)	33.7 (209)
5	23.8 (160)	22.3 (147)	20.2 (158)	25.6 (156)
Total <sup>2</sup>	28.3 (708)	32.7 (711)	28.1 (719)	33.6 (714)

†Different ( $P < 0.10$ ) from control within herd, based on unadjusted Chi-square.

\*Different ( $P < 0.05$ ) from control within herd, based on unadjusted Chi-square.

\*\*Different ( $P < 0.01$ ) from control within herd, based on unadjusted Chi-square.

<sup>1</sup>Cows were treated with once GnRH, hCG, or a CIDR insert, beginning 4 to 9 days after AI. The CIDR insert was removed 7 days later.

<sup>2</sup>A tendency ( $P = 0.11$ ) for a treatment by herd interaction. Adjusted a priori contrasts: CIDR vs. control ( $P = 0.075$ ) and hCG vs. control ( $P < 0.05$ ).

**Table 3. Conception Rates by Lactation Group in Response to Post-insemination Treatments of Progesterone (CIDR insert), GnRH, and hCG in Lactating Dairy Cows (Exp. 2)**

Lactation Number	Treatment <sup>1</sup> , % (n)			
	Control	CIDR	GnRH	hCG
First	32.8 (246)	34.9 (252)	36.0 (249)	33.2 (250)
Second	26.0 (204)	34.0 (203)	27.1 (208)	39.6**(208)
Third	26.5 (258)	31.2 (256)	22.3 (262)	29.1 (256)

\*\*Different ( $P<0.01$ ) from control within lactation number, based on unadjusted Chi-square.

<sup>1</sup>Cows were treated once with GnRH, hCG, or a CIDR insert, beginning 4 to 9 days after AI. The CIDR insert was removed 7 days later.

*Dairy Research 2006*

## OVULATION POTENTIAL OF HUMAN CHORIONIC GONADOTROPIN VERSUS GnRH

*B. S. Buttrey, M. G. Burns, and J. S. Stevenson*

### Summary

Experiments have shown human chorionic gonadotropin (hCG) to be more effective than GnRH as a means to induce ovulation of follicles. Dosages used, however, have differed greatly among experiments. A study was performed to determine the minimum effective dose of hCG needed to induce ovulation of ovarian follicles in dairy cows. Ovaries of Holstein cows were mapped by using transrectal ultrasonography 7 days before a bi-weekly pregnancy diagnosis. Cows were assigned randomly to treatments of saline, 100  $\mu$ g of GnRH (2 mL of Fertagyl, Intervet, Inc., Millsboro, NJ), or 500, 1000, 2000, or 3000 IU of hCG (0.5, 1, 2, or 3 mL of Chorulon, Intervet, Inc., Millsboro, NJ). Ovarian structures were monitored again 7 days later, and the proportion of cows, and proportion of follicles  $\geq$  8 mm in diameter, that ovulated were recorded. A dose of at least 1000 IU of hCG resulted in a greater ovulatory response than saline, GnRH, or 500 IU of hCG.

(Key Words: GnRH, hCG, Ovulation.)

### Introduction

Estrus-synchronization and ovulation-control protocols that facilitate fixed-time insemination (TAI) have been a reality for several years. Although these programs offer the opportunity to facilitate the use of TAI without detection of estrus, conception rates have historically been compromised. Most of these schemes traditionally use GnRH to control

follicular development and induce ovulation of a dominant follicle. Research has shown, however, that the human hormone hCG is more effective than GnRH at causing these follicles to ovulate. Although hCG acts to prevent luteolysis and maintain pregnancy by induction of ancillary luteal structures in humans, hCG has an LH-like activity in cattle and other species. The purpose of this study was to determine the minimum, most-effective dose of hCG needed to induce ovulation follicles  $\geq$  8 mm in diameter in cattle.

### Procedures

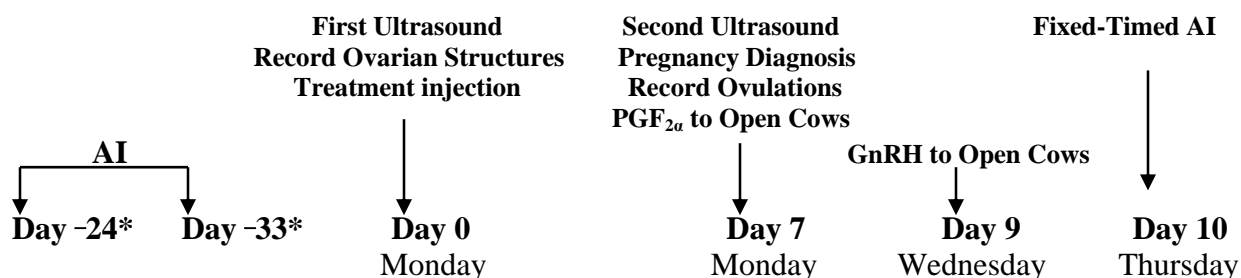
Ovaries of Holstein cows and heifers at the Kansas State University Dairy Teaching and Research Center were examined by transrectal ultrasonography, and structures were mapped, sized, and recorded. Cattle received a treatment of saline, GnRH, or one of 4 doses of hCG. Descriptions of treatments are illustrated in Figure 1. Cows were then re-examined 1 week later, and those follicles that were induced to ovulate were noted.

### Results and Discussion

Results of this experiment are summarized in Table 1. Ovulatory responses (shown as the percentage of cows with a new corpus luteum, in Table 1) per female treated with saline, GnRH, or 500 IU of hCG were exceeded ( $P < 0.05$ ) by the larger doses (1000 IU or greater) of hCG. When the combined hCG doses  $\geq$  1000 IU were compared with only saline, the  $P$  value was = 0.06. More than

95% of the females had at least 1 follicle  $\geq 8$  mm in diameter. Number of follicles at least  $\geq 8$  mm in diameter per female averaged approximately 2 in each group of females before treatment. When ovulatory response was calculated based on the total numbers of follicles, percentage responses were similar to those on a per-cow basis. Compared with saline, GnRH, and 500 IU of hCG, the greater doses of hCG produced ( $P < 0.05$ ) more ovulations. A tendency ( $P = 0.12$ ) for more follicles to ovu-

late after at least 1000 IU of hCG than after saline alone. Some ovulations in each treatment were spontaneous due to the stage of cycle at treatment, and some corpora lutea were immature at the time of first observation and were not visible until the second examination occurred 7 days later. The study shows that a dose of 1000 IU of hCG exceeds the ovulatory capacity of saline, GnRH, and the smallest dose of hCG (500 IU) in these dairy females.



\*Due to biweekly schedule, cows varied between 24 and 33 days post-AI at time of first ultrasound examination and treatment.

**Figure 1. Treatment Scheme for Monitoring Ovulatory Capacity of GnRH and Various Doses of Human Chorionic Gonadotropin, Relative to Saline Injection.**

**Table 1. Ovulatory Response 7 Days after Saline, GnRH, and hCG**

Item	Saline	GnRH	Dose of hCG, IU			
			500	1000	2000	3000
No. of dairy females <sup>1</sup>	19	18	18	18	17	16
Females having a new corpus luteum, %	42.1	50.0	44.4	66.7 <sup>a</sup>	64.7 <sup>a</sup>	68.8 <sup>a</sup>
No. of females having at least 1 follicle $\geq 8$ mm in diameter	16	18	17	18	17	15
Avg. no. follicles $\geq 8$ mm per female	1.9	1.9	1.8	1.8	1.8	2.1
Follicles $\geq 8$ mm that ovulated, %	30.0 (30) <sup>2</sup>	34.3 (35)	30 (30)	46.9 <sup>b</sup> (32)	43.3 <sup>b</sup> (30)	48.4 <sup>b</sup> (31)

<sup>a</sup>Combined doses of hCG ( $\geq 1000$  IU) tended ( $P = 0.06$ ) to differ from saline; compared with saline, GnRH, and the smallest dose of hCG, a difference ( $P < 0.05$ ) occurred.

<sup>b</sup>Combined doses of hCG ( $\geq 1000$  IU) tended ( $P = 0.12$ ) to differ from saline; compared with saline, GnRH, and the smallest dose of hCG, a difference ( $P < 0.05$ ) occurred.

<sup>1</sup>Included a few nulliparous heifers.

<sup>2</sup>No. of follicles per group.

*Dairy Research 2006*

## **MILK QUALITY AS A FUNCTION OF TEMPERATURE-CYCLED, REDUCED-FAT MILK STORED IN VARIOUS SIZE CONTAINERS**

*L. F. Julstrom and K. A. Schmidt*

### **Summary**

Packaged, reduced-fat milk was subjected to a 20 min/day temperature cycle during a 7-day refrigeration period to determine the effect on milk quality. Temperature cycling did not affect the compositional or microbial counts in reduced-fat milk stored in various package sizes. Analysis of headspace compounds during the 7 days of storage, however, showed that benzaldehyde, 2-butanone, 2-heptanone, hexanal, and octanal concentrations significantly changed, indicating that milk flavor was altered. Concentration of heptanal, a compound associated with lipid oxidation, was higher in milk packaged in half-gallon and 1-gallon containers, compared with milk packaged in 1-cup containers.

(Key Words: Milk Flavor, Packaging Size, Temperature Cycling.)

### **Introduction**

Milk consumption is increasing, partly because of new packaging. Children disliked traditional gable-top cardboard milk cartons. They found them difficult to open, leaky, or to have an odor, whereas plastic bottles were easy to open, hold, and re-close. It is known that the packaging material can impart an off-flavor in milk in as quickly as 24 hr of refrigerated storage. In addition, milk packaged in 1-pint cartons had more off-flavor than milk packaged in 1-quart or half-gallon cartons. The container-size effect has been attributed to increased surface area to volume ratio.

Today, the most common milk container is the 1-gallon, high-density polyethylene (HDPE), single-use plastic jug. These containers are designed for multiple serving times; therefore, the milk has the potential to develop off-flavors during its life at the “consumer” residence. On the other hand, milk is packaged in single-service containers ranging in size from 1 cup to 1 pint and normally in packaging material different than the HDPE 1-gallon container. Thus, it isn’t surprising that some children comment that school milk or food service milk “tastes different than milk at home.”

The Pasteurized Milk Ordinance (PMO) mandates that high-temperature, short-time (HTST) pasteurized milk must not exceed 45°F after processing. Milk stored and maintained at  $\leq 40^\circ\text{F}$  has increased shelf-life because psychrotrophic microorganisms grow more slowly, and off-flavors may not be detected for 10 to 14 days, whereas psychrotrophic microorganisms grow quickly and cause detectable off-flavors after a few days if milk is stored at 46 to 60°F. Cold milk temperature has been reported to increase by 10°F in 20 min when milk was placed at room temperature. Thus, removing milk from refrigerated storage for any period of time, such as retrieving a glass of milk for a meal, has the potential to increase off-flavors, reducing consumer acceptability. Hence, the objective of this study was to evaluate reduced-fat milk quality as a function of carton size and temperature cycling during a 7-day period.



## Procedures

Reduced-fat milk was obtained within 2 days of production from the Kansas State University dairy plant, packaged in 1-cup, half-gallon, or 1-gallon plastic (HDPE) containers. Milk was processed at  $174 \pm 1^\circ\text{F}$  for 20 seconds and homogenized at  $1500 \text{ lb/in}^2$  (psi). Reduced-fat milk samples were then placed in brown paper bags and stored at  $40^\circ\text{F}$ . For 7 consecutive days, milk samples were removed from refrigerated storage and placed in a  $72^\circ\text{F}$  incubator for 20 min. Five ounces of milk was removed from the 1- and half-gallon containers, which were then replaced in  $40^\circ\text{F}$  storage. For the smallest container size, 1 cup, an individual container carton was used each day, but cycled the correct number of times. Milk samples were analyzed for headspace composition, microbial counts, and chemical contents, according to standardized, published procedures. The experiment was repeated 3 times, and resulting data were analyzed statistically. Results are presented from days 0, 2, 4, and 7.

## Results and Discussion

**Temperature Change.** Table 1 displays the average temperature of the milk samples after the 20-min temperature cycle, as a function of container size. The average temperature increase by container size was: 1.7, 2.9, and  $8.3^\circ\text{F}$  for 1 gallon, half gallon, and 1 cup, respectively. The smallest container size was affected more by temperature cycle than the larger containers. The temperature increase did not exceed the upper cap in the PMO for the 1- and half-gallon containers, but did for the 1-cup containers. It was expected that a trend would occur that milk temperature would increase over time, as milk was removed from the 1- and half-gallon containers each day (5 ounces for testing), but that did not occur, perhaps because the 1- and half-gallon milk containers still contained about

73% and 45%, respectively, of their original volumes at the end of the study.

Observed temperature change in our milk samples was not as dramatic as in previous reports, perhaps because of controlled temperature conditions we employed. It has been reported that many home refrigerators are not maintained at  $\leq 40^\circ\text{F}$ , but rather approach the upper level of the refrigerated temperature definition of  $45^\circ\text{F}$ . In some situations (perhaps late spring and early fall), “room temperature” may exceed  $72^\circ\text{F}$ . These 2 differences could contribute to a larger temperature change than was observed in our study.

**Compositional and Microbial Analyses.** Milk samples did not differ in compositional or microbial quality. Mean compositional contents for the reduced-fat milk were 1.96% fat and 10.9% total solids. Microbial counts did not differ either, as all total plate counts were  $\leq 500/\text{mL}$ , even at the end of the study. The compositional and microbial data agree with the temperature data. The cycling treatment did not induce great ( $\geq 20^\circ\text{F}$ ) temperature fluctuations in the milk samples; thus, microbial counts probably would not increase dramatically during a 7-day storage period. Previous research has indicated that microbial numbers need to approach or exceed  $10,000,000/\text{mL}$  to degrade milk components to such an extent that certain off-flavors can be detected.

**Headspace Analysis.** More than 35 peaks were obtained on each chromatogram from the reduced-fat milk samples. From these peaks, 7 headspace compounds were identified and quantified in most samples: benzaldehyde, 2-butanone, heptanal, 2-heptanone, hexanal, octanal, and pentanal. These compounds have been reported in the past to be present in both fresh milk and milks with off-flavor. Some headspace compounds, such as hexanal, have been implicated in off-flavored milks, such as those having oxidized flavor.

Statistical analysis indicated that headspace concentrations were not affected by container size or temperature cycle, but were affected by day, indicating that reactions were on-going throughout the study. These differences are shown as significant means for headspace compound concentrations as a function of day in Table 2. Results indicate that the quantities fluctuated throughout the study, not always showing a steady increase or decrease, which is in agreement with other studies. Many of these compounds are reaction compounds and, in turn, become a substrate for another degradative reaction. Heptanal concentration varied slightly throughout the 7-day storage period, which wasn't expected. Previous research indicated that heptanal concentration would not change if milk was protected from light during a 6-week storage period. Because our milk samples were protected from light by placement in a brown paper bag at all times (to identify the temperature cycling effect only), we suggest that heptanal concentration could be affected by time, and the frequency of testing may be critical in verifying that effect. Pentanal concentration remained consistent throughout the study (average of about 0.994 mg/mL). Pentanal has been reported to remain consistent, provided milk remained at refrigerated temperatures of 35.6 to 41°F. Although the temperature cycling did allow for this temperature range to be exceeded in the half-gallon and 1-cup containers, perhaps the higher temperature was not sustained for sufficient time to affect the pentanal concentration.

The milk containers used in the study were made from similar materials – a result of addressing student complaints about school lunch milk. Our research showed that headspace compound concentrations did not differ, regardless of container size, except for heptanal. Reduced-fat milk packaged in 1-cup containers had less heptanal than reduced-fat milk packaged in 1- or half-gallon container.

Heptanal is a product of the oxidation reaction, which can be initiated by light, metal, or oxygen exposure. Although milk was protected from light, over time, the 1- and half-gallon containers had an “air space” above the milk, especially by the end of the study, suggesting that perhaps the oxygen in the air space above the milk catalyzed the oxidation reaction. The fact that the container size wasn't a factor in our study refutes previous research that container size was an important contributor to the milk flavor. Differences in experimental design, packaging materials, and storage conditions could be responsible for the differences reported.

Headspace compound concentrations were not affected by temperature cycling in this study, which wasn't expected. Other researchers have reported, however, that the milk processing and storage temperatures were primary factors related to headspace compound concentrations in stored milk. Our work seems to support this, because our experimental design was set to maintain and control the milk processing and storage temperatures. Our overall results indicate that milk packaged in single-service containers similar to the commercial, plastic (HDPE) 1- and half-gallon milk containers was similar to milk packaged in larger, multiple-use milk containers.

**Conclusions.** Temperature cycling did not affect volatile compound concentration, compositional contents, or microbial counts in reduced-fat milk packaged and stored in various carton sizes. Temperature cycling seemed to have no effect on the growth of microorganisms, perhaps because the milk temperature increase did not exceed a 9°F differential. Heptanal concentration was greater in reduced-fat milks packaged in 1- and half-gallon containers than in reduced-fat milk packaged in 1-cup containers. Headspace compound concentrations were affected by time rather than by container size or temperature cycle.

Perhaps the time (20 min) or the temperature increase (1.2 to 9.6°F) were not sufficient to catalyze reactions that would result in great changes of headspace compound concentra-

tions. Further work is needed to see if headspace compound concentrations increase with extended storage or extended temperature cycling.

**Table 1. Average Temperature of Reduced-fat Milk Packaged in Various Container Sizes after a 20-minute Exposure to Room Temperature during 7 Days of Storage<sup>1</sup>**

Container Size	Days of Storage			
	0	2	4	7
	Temperature, °F			
1 gallon	42.8	41.5	41.2	41.4
½ gallon	43.5	43.0	42.0	43.3
1 cup	47.1	48.7	47.7	49.6

<sup>1</sup>72°F for 20 min each day for 7 consecutive days.

**Table 2. Mean Headspace Compound Concentrations (mg/mL) of Various Flavor Compounds Associated with Temperature-cycled Reduced-fat Milk during 7 Days of Storage<sup>1</sup>**

Headspace Compound	Days of Storage			
	0	2	4	7
	Means ± SD (n = 9)			
Benzaldehyde	0.899 ± 0.009 <sup>a</sup>	0.895 ± 0.009 <sup>ab</sup>	0.874 ± 0.009 <sup>b</sup>	0.877 ± 0.009 <sup>ab</sup>
2-Butanone	0.751 ± 0.176 <sup>b</sup>	0.976 ± 0.176 <sup>a</sup>	0.923 ± 0.176 <sup>a</sup>	0.846 ± 0.176 <sup>ab</sup>
Heptanal	0.739 ± 0.004 <sup>a</sup>	0.737 ± 0.004 <sup>a</sup>	0.732 ± 0.004 <sup>b</sup>	0.734 ± 0.004 <sup>ab</sup>
2-Heptanone	0.454 ± 0.001 <sup>a</sup>	0.453 ± 0.001 <sup>ab</sup>	0.452 ± 0.001 <sup>b</sup>	0.453 ± 0.001 <sup>b</sup>
Hexanal	0.431 ± 0.002 <sup>a</sup>	0.433 ± 0.002 <sup>a</sup>	0.425 ± 0.002 <sup>b</sup>	0.426 ± 0.002 <sup>ab</sup>
Octanal	0.892 ± 0.035 <sup>a</sup>	0.830 ± 0.036 <sup>b</sup>	0.747 ± 0.038 <sup>c</sup>	0.818 ± 0.036 <sup>b</sup>

<sup>a,b,c</sup> Means within row having different superscripts differ ( $P < 0.05$ ).

<sup>1</sup>Temperature was 72°F for 20 min each day for 7 consecutive days.

## EVALUATE THE EFFICACY OF “HEAT STRESS AUDITS” OF YOUR COOLING SYSTEM THROUGH CORE BODY TEMPERATURE

*J. F. Smith, M. VanBaale<sup>1</sup>, C. Jamison<sup>2</sup>, R. Rodriguez<sup>2</sup>,  
M. J. Brouk, and J. P. Harner*

### Summary

A project to evaluate the degree of heat stress in individual dairies was carried out in the summer of 2005. The object of this project was to develop a method to evaluate or audit how effective an individual dairy is in managing heat stress. Approximately 45 herds in 20 different states were audited for the degree of heat stress cows experienced during a 72-hr period. Dairies were selected based on geography, climate, and facility design. Lactating cows 40 to 100 days in milk (DIM) and dry cows within 30 days of calving were evaluated. Vaginal temperatures of 8 cows located in the same group were collected every 5 min by using data loggers (HOBO U12<sup>®</sup>) attached to a vaginally placed insert (blank CIDR<sup>®</sup>). Ambient climatic data were collected on the project dairies by using logging devices that collected temperature and relative humidity at 5-min intervals. Census data were collected at each dairy, and included pen sizes, milking frequency, milking times, average milk production, DIM, parity, holding-pen design, and timing of cow movements. Data were imported into Excel (Microsoft, Redmond, WA) as individual cow files aligned by time. The data for an individual cow were then averaged with all other cows in the pen in hourly increments over a 24-hr period. Each hour of the 24-hr period is then a summary of that hour on

3 consecutive days, with 8 devices contributing 12 points per hour per day to the summary. So each hour is a summary of 12 data points  $\times$  8 cows  $\times$  3 days, or 288 data points per hour. Information was summarized graphically in PowerPoint (Microsoft, Redmond, WA) and presented to the individual producers, along with recommendations on how to improve their heat-stress abatement practices. The project was not designed as a controlled experiment; therefore, caution is advised in over-interpreting the results. That being said, the project does demonstrate the feasibility and usefulness of using intra-vaginal temperature recording to monitor how well an individual dairy is managing heat stress.

(Key Words: Body Temperature, Cooling, Heat Stress.)

### Introduction

Effects of heat stress on animal production are well known and have been investigated and documented for a number of years. It is commonly accepted that a temperature humidity index (THI)  $\geq$  72 creates a stressful environment for lactating dairy cattle. When ambient temperature conditions approach body temperature, the only viable route of heat loss is through evaporation. If ambient conditions

---

<sup>1</sup>University of Arizona, Tucson, AZ..

<sup>2</sup>Monsanto Dairy Business, St. Louis, MO.

exceed body temperature, heat flow will reverse and an animal will become a heat sink. Therefore, estimating the impact of the thermal environment around animals is necessary to understand their cooling needs. Because of the typical location of cooling equipment relative to animals, and the large variety of animal positions and locations, a wide range of microenvironments exist within a facility. As a consequence, cows experience differing degrees of heat stress within a day. Thus, accurately determining the degree of heat stress a cow experiences over time is a challenge.

### **Heat Stress Audits 2005**

During the winter of 2005, a project was designed to record intravaginal temperatures of lactating and dry mature dairy cows by using a continuous temperature logging device (Hobo U12 Stainless Temperature Data Logger, Onset Computer Corporation Bourne, MA) attached to a blank intravaginal insert. The observational period was 72 hr, and temperatures were recorded at 5-min intervals. Cows were selected according to days in milk (DIM) and milk production, or days carried calf for dry cows. The data loggers were inserted into 8 cows per pen. Census data collected at each dairy site included pen size, milking frequency, milking times, average milk production, holding-pen facility design, and timing of cow movements. Ambient temperature and humidity were collected at the dairies by using logging devices that collected temperature and relative humidity at 15-min intervals over the same 72-hr period as the data loggers. If ambient devices were not available, outside temperature and relative humidity data were gathered by using global positioning system (GPS) coordinates of the facility and WeatherPlot. Data were downloaded from each intravaginal insert. All data were aligned by 5-min intervals and then imported into Microsoft Excel. The individual device data was then collapsed in a pivot table

to be examined in hourly increments over a 24-hr period. Each hour of the 24-hr period represents a summary of that hour on 3 consecutive days, with 8 devices contributing 12 data points/hour/day. Specifically, each hour is a summary of 12 data points  $\times$  8 cows  $\times$  3 days, or 288 individual data points within that hour.

### **Results and Discussion**

During this collaborative effort, data were collected in 20 states, from more than 45 herds, from dairies milking approximately 125,000 cows. A consistent observation throughout the auditing was the impact of holding-pen cooling or the lack thereof. A holding pen (designed to allow 15 ft<sup>2</sup>/cow) without proper cooling is an area where dairy cows may experience severe heat stress (Figure 1). If the holding pen is properly cooled, however, vaginal temperatures will be reduced each time cows are brought to the milking parlor (Figure 2). Another observation was the impact of shade, compared with no shade (Figure 3). Lactating cows provided with shade had lower core body temperature during the hottest times of the day, compared with those without shade. It is no surprise that the benefit from shade was greatest when outside temperatures were the hottest. Implementation of feed-line misters without shade was compared with shade alone, and shade alone maintained lower core body temperature than misters alone (Figure 4).

Audits also can be used to evaluate different types of cooling systems. Figure 5 contains the results of comparing two Korral Kool systems and one oscillating fan and mister system. The observations on this particular herd were impressive in that core body temperature was lowest for cows housed under the 5-Hp Korral Kool system and highest for those housed under the 2-Hp Korral Kool system. The core body temperature of cows

housed under the ADS-ST fans was intermediate, suggesting that the 5-Hp system was doing a better job of maintaining core body temperature than fans were. Fans, however, seemed to be out-performing the 2-Hp Korral Kool system.

As mentioned earlier, we collected data from a variety of facilities throughout the summer of 2005. Within a facility, the minimum, average, and maximum core body temperature temperatures from all cows were collected, but only averages were typically reported. Figure 6, however, shows both the average, minimum, and maximum core body temperatures observed from 8 multiparous cows housed in a tunnel-ventilated barn with evaporative pads in western Kansas. Regardless of the time of day and outside ambient temperature ( $80 \pm 10^\circ\text{F}$ ), the maximum core body temperature was never more than  $1^\circ\text{F}$  higher than the minimum, and overall average core body temperature did not exceed  $102.4^\circ\text{F}$ . This audit demonstrates the value of providing a cooler environment for the cow.

One primary goal of this project was to develop a system that could be used to evaluate how well heat stress is managed. Gathering and attempting to understand data from a wide array of differing facilities, in different climates, and with different production levels

and management schemes is intended to allow us to move forward into more-specific targeted use of the recording devices in subsequent summers. In general, our results tended to agree with what our current knowledge predicted, (i.e., cows get hot when climatic and management factors subject them to conditions that exceed their inherent ability to dissipate heat generated and absorbed). These data should allow us to refine our expectations. Observations from this project indicate that the data loggers are an effective tool to monitor and ultimately fine tune currently installed heat abatement systems, as well as suggesting a need for future improvement. More work needs to be done to completely understand the problem. As new technologies come to market, however, these data should prove useful in answering questions of how and when such technology can fit into a particular dairy production system. This technology allows core body temperature to be monitored and recorded 24 hr per day as cows move throughout a facility. Using a core body temperature probe to continuously monitor vaginal (core body) temperature allows an accurate determination of where and when cows experience the most heat stress. As a consequence, management decisions can be made to improve cooling and reduce heat stress, thus improving cow performance.

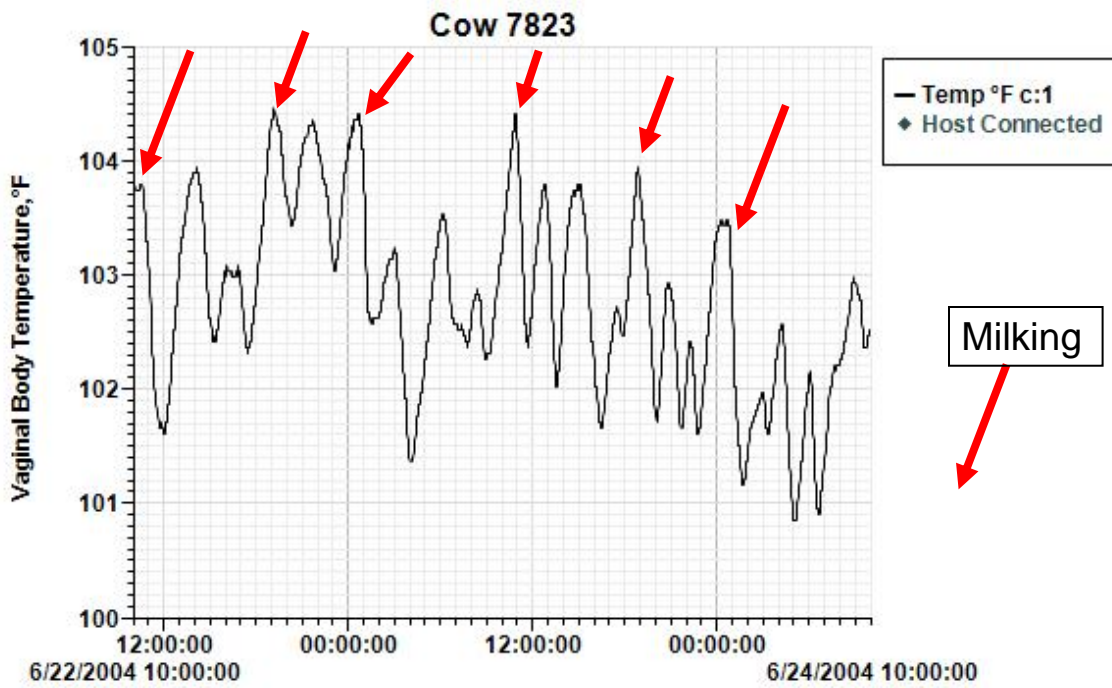


Figure 1. Two 24-hr Periods of Core Body Temperature from a Single Cow in a Holding Pen.

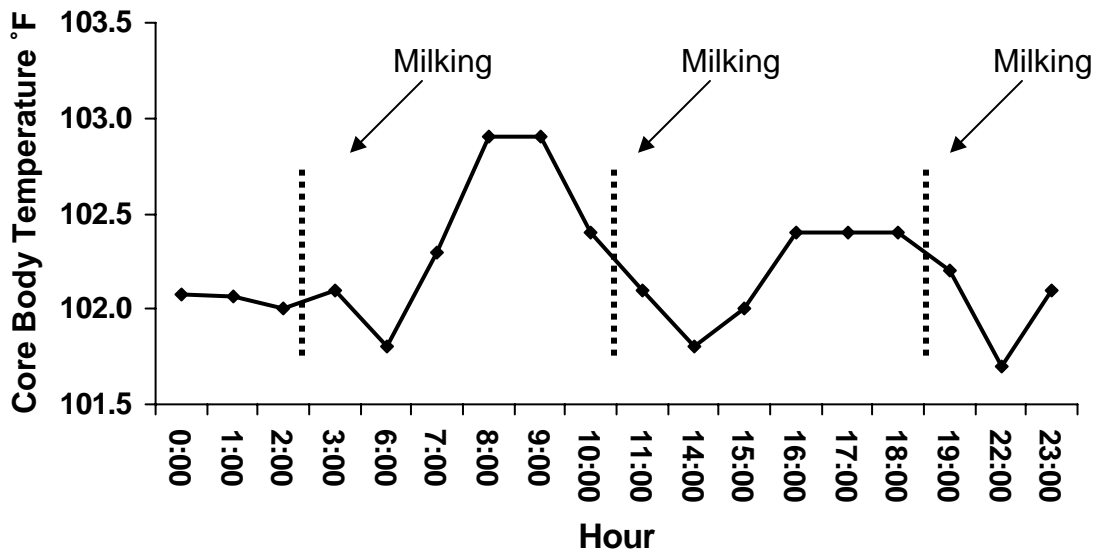


Figure 2. Effects of Core Body Temperature of Cows Experiencing Excellent Cooling of Holding Pen and Parlor Exit Lane.

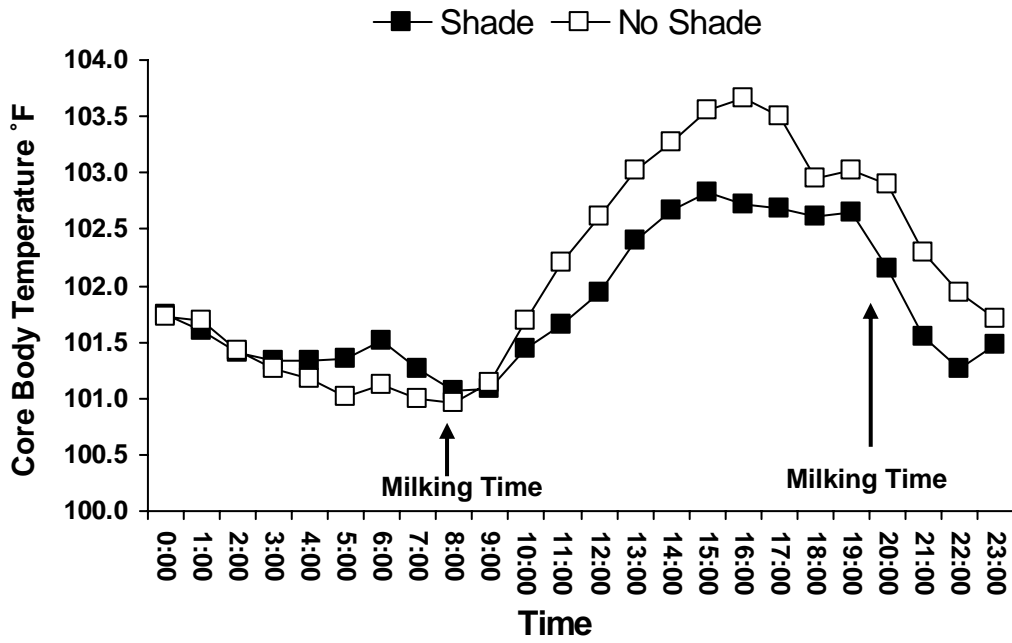


Figure 3. Core Body Temperature, With or Without Shade.

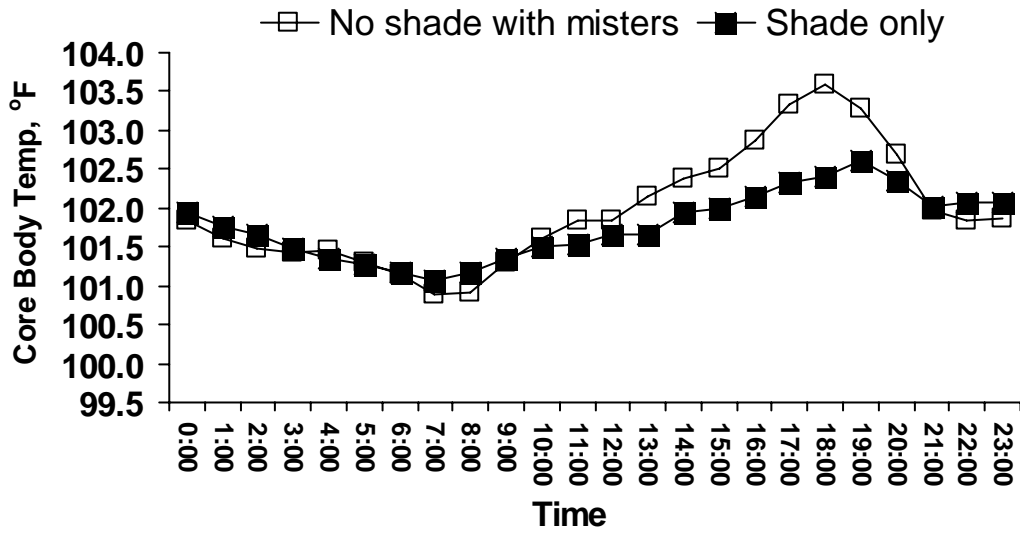


Figure 4. Impact of Core Body Temperature for Close-up Dry Cows Provided Shade, With and Without Feed-line Misters.



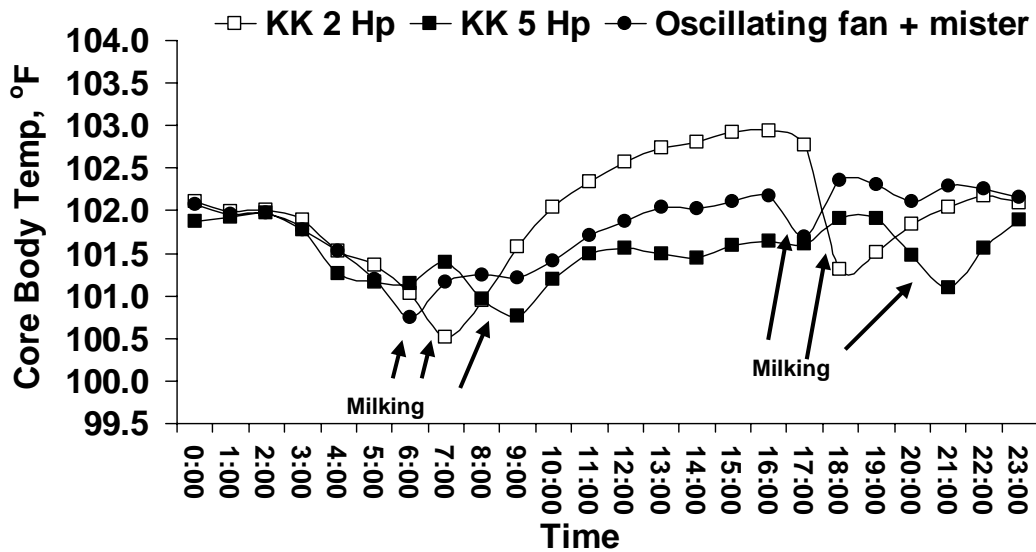


Figure 5. Effects of Core Body Temperature of Multiparous Lactating Cows Housed in a Dry Lot Facility with 2- or 5- Hp Korral Kool Coolers or Oscillating Fans with Misters.

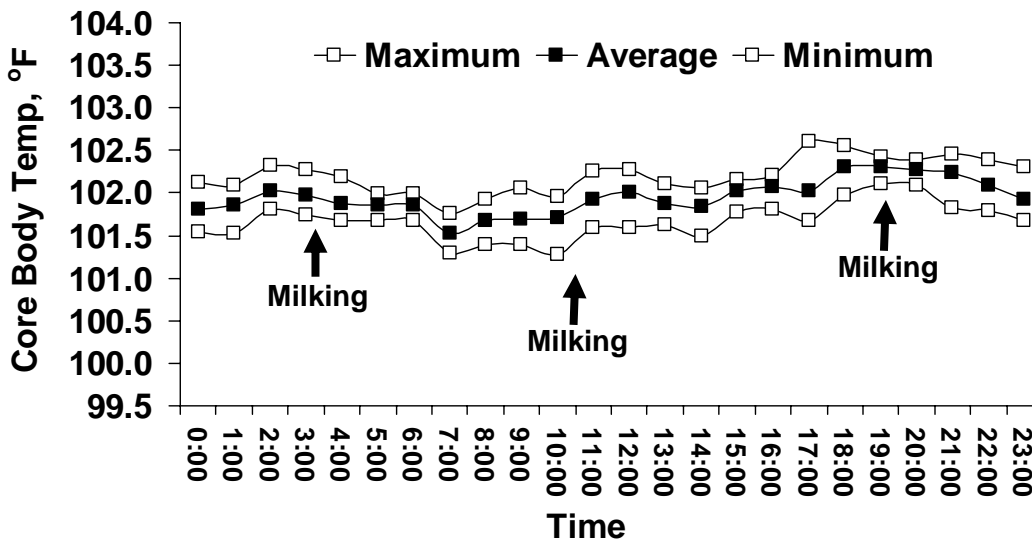


Figure 6. Core Body Temperature of Multiparous Lactating Cows Housed in a 4-row Tunnel Ventilated Freestall Barn.

*Dairy Research 2006*

## CONSUMPTIVE WATER USAGE OF EVAPORATIVE PADS

*C. Schmidt<sup>1</sup>, J. F. Smith, M. J. Brouk, and J. P. Harner<sup>1</sup>*

### Summary

Consumptive water usage by evaporative pads was measured during 7 days of a 3-week period at a Kansas (KS) dairy and a 2-day period at a North Dakota (ND) dairy. Water meters were installed between the water hydrants, and evaporative pads at each dairy, and were monitored. Data were recorded every 30 minutes during 5 hr at the KS site and every 15 minutes during 1 to 2.5 hr at the ND site. Ratio of pad area to cow equaled 4.8 and 4.5 ft<sup>2</sup> per cow at the KS and ND sites, respectively. Airflow rates through the pads were 1.2, 2.1, and 3.2 mph at the ND dairy and 3.3 mph at the KS dairy. During the study period in KS, the temperature humidity index ranged from 78 to 86 and water usage varied from 0.7 to 4.7 gallon per minute. Average pad efficiency equaled 62%. Water usage averaged 0.3 gallons per hr per ft<sup>2</sup> of pad when airflow rate was 3.3 to 3.6 mph. At the ND dairy, the water usage averaged 0.1, 0.3, and 0.38 gallon per hr per ft<sup>2</sup> of pad for the low, medium, and high airflow rates, respectively. The temperature humidity index equaled 65, 72.5, and 71 for the low, medium, and high airflow study periods. Pad efficiency averaged 93, 86, and 81% from the low to high airflow rates. Similar to pad efficiencies at the KS site, efficiency increased as the outdoor air temperature decreased.

(Key Words: Cooling Systems, Evaporative Cooling, Water Usage.)

### Introduction

Consumptive water use for heat abatement increases the daily water requirements of a dairy during summer. Water usage depends on weather conditions, heat abatement system, and operational characteristics. Water demand for a low-pressure soaker system is based upon nozzle capacity and spacing, in addition to the number of nozzles simultaneously functioning. Water usage is determined by how frequently the nozzles spray water over the cow's back. In general, frequency is a function of outdoor air temperature. Low-pressure systems cool the cow by evaporating water from the body surface. Evaporative cooling systems cool the air around a cow's body to help minimize heat stress. There is little information on the water demand and water usage of evaporative pads. The objective of this study was to determine consumptive water usage of evaporative cooling systems.

### Procedures

Water meters were installed on 2 dairies that use evaporative cooling. Dairy 1 was located in northeast KS, with a 110-cow facility. This dairy used two, 6-ft-wide pads. Pad 1 (south pad) was 20 ft long and Pad 2 (north pad) was 60 ft long. Water was supplied to each pad through a 1-inch water hydrant. Meters were installed between the hydrant and evaporative pad to measure water usage. Wa-

---

<sup>1</sup>Department of Biological and Agricultural Engineering.

ter usage was collected at 30-minute intervals between 1:00 and 6:00 p.m. on 7 days between July 18 and Aug 10, 2006. Ratio of pad area to cow was approximately 4.8 ft<sup>2</sup> per cow.

Dairy 2 was an 800-cow unit located in southeast ND. This dairy used 12 sections of pads, with a 1-inch water hydrant serving 4 sections of pads. Each pad section was 5 ft wide and ranged in length from 57 to 67 ft. There were 2 rows of pads stacked on top of each other to form a pad 10 ft wide by 365 ft long. Water meters were installed between the hydrant and pads, and data were collected every 15 minutes during 2 hr. Data were only collected during 3 periods because of a main water line malfunction. Airflow rate through the pad was adjusted during each period. The pad area to cow ratio was equal to 4.5 ft<sup>2</sup> per cow. The 3 airflow rates evaluated were 3.2, 2.1, and 1.2 mph per ft<sup>2</sup> of pad.

## Results and Discussion

Figure 1 shows the water usage during the 30-minute intervals at Dairy 1. Average water used during a 30-minute interval was 75 gallons. Temperatures averaged 103°F on July 19 and the relative humidity was 30%, which is reflective of the highest water usage. The temperature humidity index on July 19 was 85.5. The lowest water usage was on Aug 10, when the average temperature and relative humidity were 83°F and 73%, respectively. The temperature humidity index on Aug 10 was 80. The increase in relative humidity resulted in the air being able to absorb less moisture. The greatest water demand for the dairy occurred between 3:30 and 5:00 p.m., when, in addition to the consumptive water used by the pads, milking equipment was also in operation. Water supply at the dairy was not able to meet the demands of the milking equipment and the pad, thus there was a de-

cline in water usage during this period (Figure 1).

Average daily water used by the pads was 1.65 gallons per hr per cow during a period from July 18 to August 10. Pad water usage equaled 0.30 gallons/hr per ft<sup>2</sup> of pad. Pad 2 equaled 75% of the total pad length, but only 68.5% of the water used was metered through this pad. The remaining 31.5% was used by Pad 1. This slight difference may have occurred because of some water leaks in Pad 1 or exposure of Pad 2 to the prevailing weather, which caused some drying of the pad.

Figure 2 shows the relationship between outdoor air temperature and relative humidity and temperature humidity index. Average temperature humidity index was  $82.7 \pm 1.6$  during the 7 monitoring periods. Cooling efficiency of the pad was calculated by using psychometric properties of the air. Efficiency was based on the ratio of actual water metered to water required to raise the relative humidity of the incoming air to 100% or the saturation point. Figure 3 shows the relationship between outdoor air temperature and pad efficiency. The average pad efficiency was  $61.8 \pm 19.2\%$ . Actual pad efficiency was probably greater because metered water included water leakage. As the outdoor air temperature increased, the pad efficiency decreased (Figure 3). In other words, as the temperature increased and humidity decreased, more moisture probably was absorbed by the air, but the volume and velocity of the air through the pad may have limited the amount of moisture absorbed. Efficiency might increase if pad thickness or area were increased, assuming no increases in air movement or volume, or a decrease in air movement and volume for given pad properties.

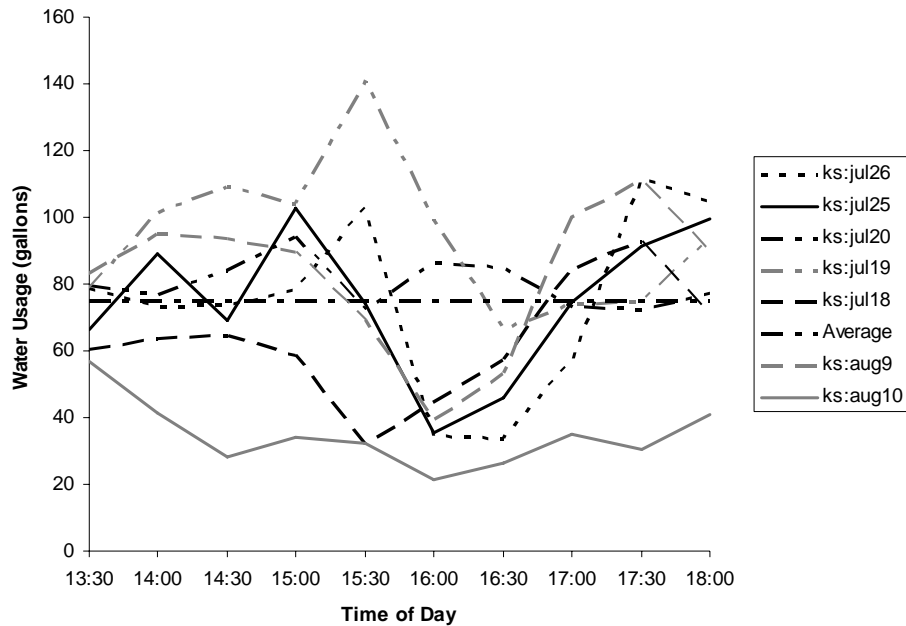
Consumptive water usage at the ND dairy equaled 30.1, 91.5, and 115.7 gallons per 15

minutes for the low, medium, and high airflow rate studies, respectively. Measured airflow rates through the pad averaged 1.2, 2.1, and 3.2 mph for the low, medium, and high airflows, respectively. On a per-cow basis, water usage was 0.45, 1.37, and 1.75 gallons/hr per cow while the evaporative pad was operating. Figure 4 shows a comparison of the water used per ft<sup>2</sup> of pad for the KS and ND sites. Similar water usage was observed between the KS dairy and the medium airflow rate at the ND dairy. Measured airflow rates were 3.3 mph through the pads at the KS site and 3.6 mph during the medium airflow rate study at the ND dairy. Water usage by the pad did not increase in proportion to the airflow rate. When the high and medium airflow rates were compared, the difference in air velocity was 47%, but the increase in pad water usage was only 27% greater. Pad efficiency averaged 93, 86, and 81% for the low, medium, and high airflow rates, respectively.

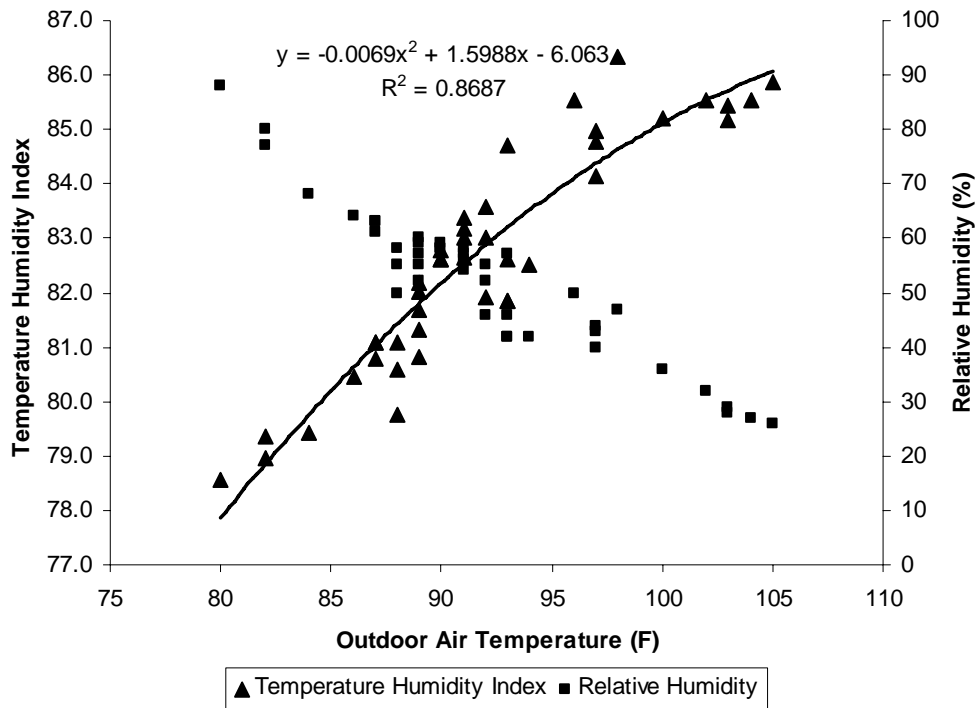
temperature decreased at the ND dairy. Pad efficiency during the period with medium airflow rate may have been influenced by a 20-mph wind from the southeast blowing into the pads. Water leakage at the KS dairy seemed, by visual observation, to be greater than that at the ND dairy. Some of the difference in evaporative pad efficiencies between the 2 sites may be explained by water leakage. Pad efficiencies decreased as water leakage increased; therefore, maintenance is critical to prevent excess water usage.

Water usage by evaporative pads was measured at 2 dairies during summer 2006. Water usage was approximately 1.75 gallons/hr per cow when 100% of the fans were operating during hot weather. Results of this study, in which there was between 4 and 5 ft<sup>2</sup> of pad per cow, suggest that water demand and supply should be designed based on an average consumptive usage of 0.33 gallons/hr per ft<sup>2</sup> of pad area.

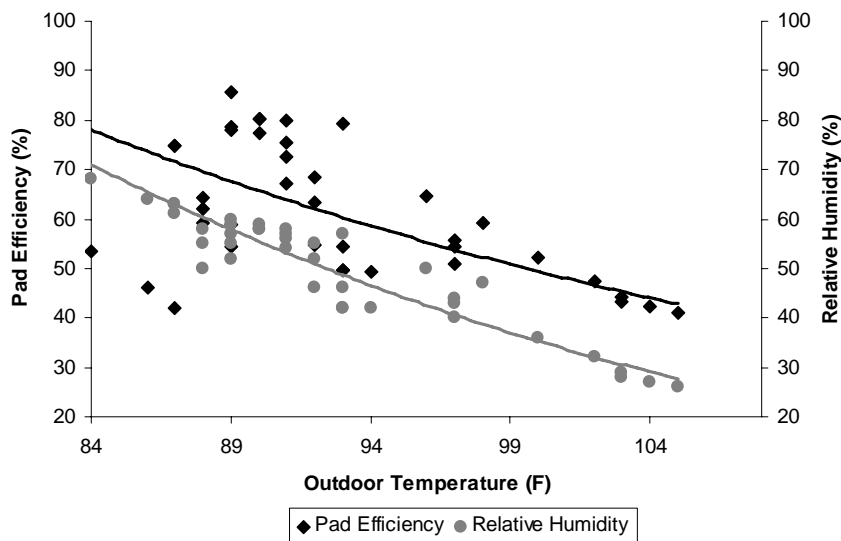
Similar to the pad efficiencies at the KS site, efficiency increased as the outdoor air



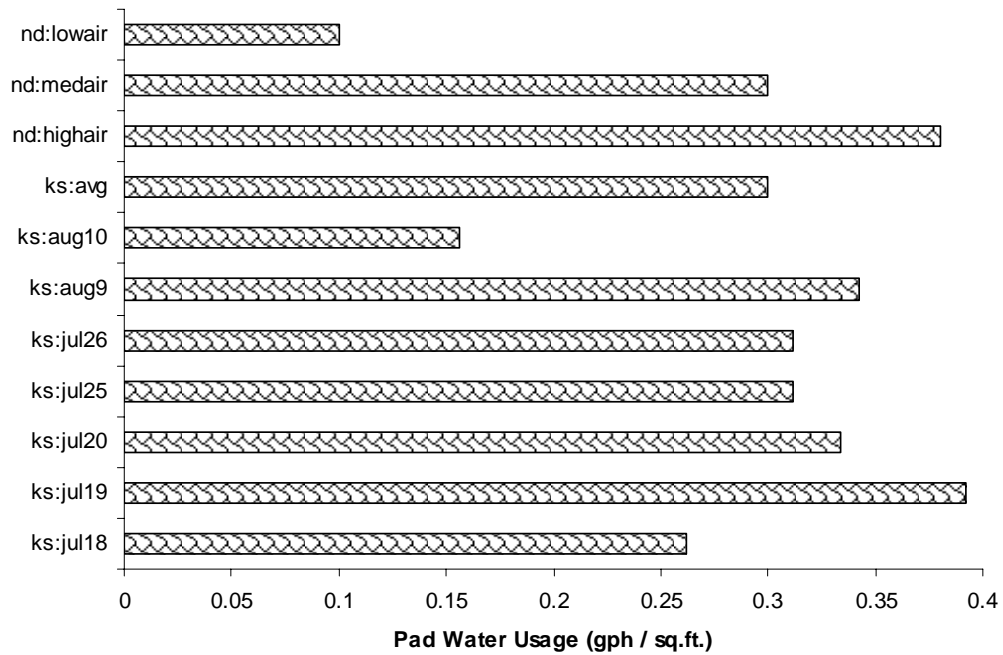
**Figure 1. Water Usage by the Evaporative Pads during 30-minute Intervals at the KS Dairy.**



**Figure 2. Relationship Between Temperature and Temperature Humidity Index during the Study Period at the KS Dairy.**



**Figure 3. Influence of Outdoor Air Temperature on Evaporative Pad Efficiency.**



**Figure 4. Comparison of Evaporative Pad Water Usage during All of the Monitoring Periods at the KS and ND Dairies.**

*Dairy Research 2006*

## CHARACTERISTICS OF LOW-PROFILE CROSS-VENTILATED FREESTALLS

*J. P. Harner<sup>1</sup>, J. F. Smith, and R. Millner<sup>2</sup>*

### Summary

The first low-profile cross-ventilated (LPCV) freestall building was stocked in fall 2005 in North Dakota. There currently are 3 other LPVC freestalls operational and 6 others under construction. The LPCV building offers some of the advantages of natural ventilated and tunnel ventilated freestalls. Natural or conventional tunnel ventilation buildings normally have from 2 to 6 rows of freestalls. The first LPCV building was an 8-row configuration, but wider LPCV buildings with 10, 12, 16, or 24 rows of freestalls are being considered. Low-profile cross-ventilated freestall buildings are another option for dairy cattle housing. These facilities allow producers to have more control over the cow's environment during all seasons of the year. They also allow cows to be located closer to the milking parlor, reducing time away from feed and water.

(Key Words: Cooling Systems, Cross Ventilation.)

### Characteristics

The low profile results from the roof slope being changed from a 3/12 or 4/12 pitch common with natural ventilated buildings to 0.5/12 or 1/12 pitch. Figure 1 shows the difference in ridge height between 4-row natural ventilated buildings and an 8-row LPCV

building. Contractors are able to use conventional warehouse structures with the LPCV building, which reduces the cost of the building. The interior components and space per cow for resting, socializing, and feeding in a LPCV building is similar to a 4-row building. Figure 1 illustrates the differences in land space requirements between the two, 4-row natural ventilated freestall buildings and an 8-row LPCV building.

Many dairies are currently tunnel ventilating freestall buildings. The traditional tunnel ventilation has moved air parallel to the ridge of the building. The challenge remains how to maintain air in the cow space. The air tends to move toward the alleys, ceiling, or feed lane, where there is no interference from cows. Some dairies have installed baffles to redirect air into the cow space. The bottom of the baffle, however, cannot interfere with normal operation of the bedding and feeding equipment. The LPCV building moves air perpendicular to the ridge or across the building. Because air is moving across the building, the baffles may be strategically located to move air back into the cow space without interfering with equipment. The bottom of the baffle is 8 to 10 feet above the floor, depending on the number of baffles. This compares with 12- to 13-ft openings in tunnel-ventilated freestalls. Baffle design and placement is critical to minimize the static pressure encountered by the fans. As static pressure increases, fan per-

---

<sup>1</sup>Department of Biological and Agricultural Engineering.

<sup>2</sup>Owner of MCC Dairy, Veblen, SD.

formance decreases. The LPCV building is continuously ventilated mechanically, so emergency backup power must be available.

Figure 2 shows an end view of an 8-row LPCV building. Pads are placed continuously along one side of the building, and fans are placed on the opposite side. There is more space available for placement of fans and evaporative pads parallel to the ridge rather than perpendicular because the equipment doors typically are placed in both end walls. Figure 3 shows a layout of an 8-row LPCV building with tail to tail freestalls. From a top view, this design simply places two 4-row freestall buildings side by side and eliminates the space between the buildings for natural ventilation. One potential advantage of the LPCV or tunnel ventilated buildings is that cows are exposed to nearly constant wind speeds. Inside the building, the air velocity or wind speed will normally be less than 8 mph during peak airflow. The ventilation rate is reduced during cold weather, so wind speed is reduced to less than 2 mph.

During warm weather, the air exchange rate is 60 to 90 seconds. An air exchange is equivalent to replacing all of the air inside the building with fresh air. If the air exchange rate is 60 seconds, then every 60 seconds the fans are moving enough air to completely exchange the air inside the building with outdoor air. The air exchanged is reduced during the winter months. The LPCV building in North Dakota currently has a winter-time exchange rate of 180 to 240 seconds. This facility is managing airflow rates based on ammonia concentrations rather than air temperatures, because average wind speed through the building is less than 1 mph. Measured ammonia emissions at the exhaust fan were between 1.2 and 1.5 ppm, depending on the air exchange rate.

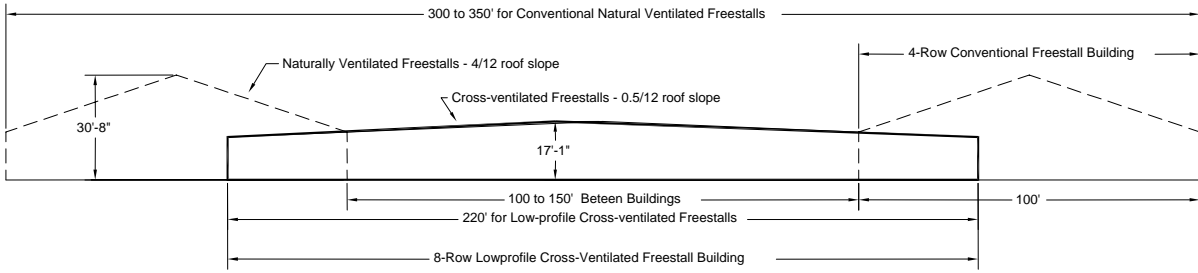
Most dairies exploring the LPCV building are using a scrape system for manure man-

agement. The building manufacturer should be contacted before selection of a manure system. Buildings may be flushed if placed on a 2 to 3% slope. There may be some structural concerns, however, due to shifting rain and snow loads. Depending on roof design and materials selected, some rain or snow may flow to the lower end of the building rather than toward the edge. This creates additional loads near the lower end of the building.

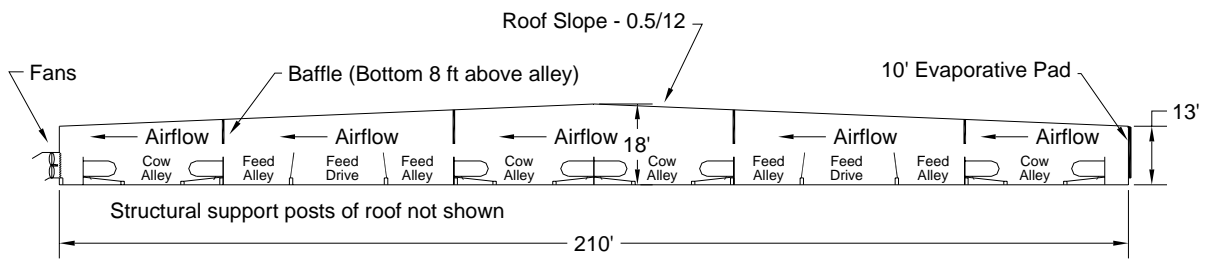
Proper lighting in LPCV building is important because no natural light exists. Research indicates that 10 to 15 foot candles of light are necessary for milk production. High and low bay metal halide light fixtures may not be suitable because of lower fixture mounting heights. Mounting height is determined by the distance from the bottom of the fixture to the work surface. In a freestall building, the work surface is better defined by the top of the loops or feed rail. Most metal halide lights recommend, for optimum light distribution, that the mounting height be 12 to 20 feet, depending on the fixture. The mounting height for florescent lights is 6 to 12 ft, which is better suited for the LPCV buildings. The lighting should be designed based on 25 foot candles of light throughout the building, rather than 10 to 15 foot candles. Bulb lumens or light output tends to decrease over time, especially as fixtures accumulate dust and fly specks. Additional lighting in the building also will create a better environment for employees to perform their tasks.

Low-profile cross-ventilated freestall buildings are another option for dairy cattle housing. These facilities allow producers to have more control over the cow's environment during all seasons of the year. They also allow cows to be located closer to the parlor, reducing time away from feed and water. The footprint of these facilities is smaller than naturally ventilated facilities. Additional research trials are in process to determine the viability of LPCV buildings.

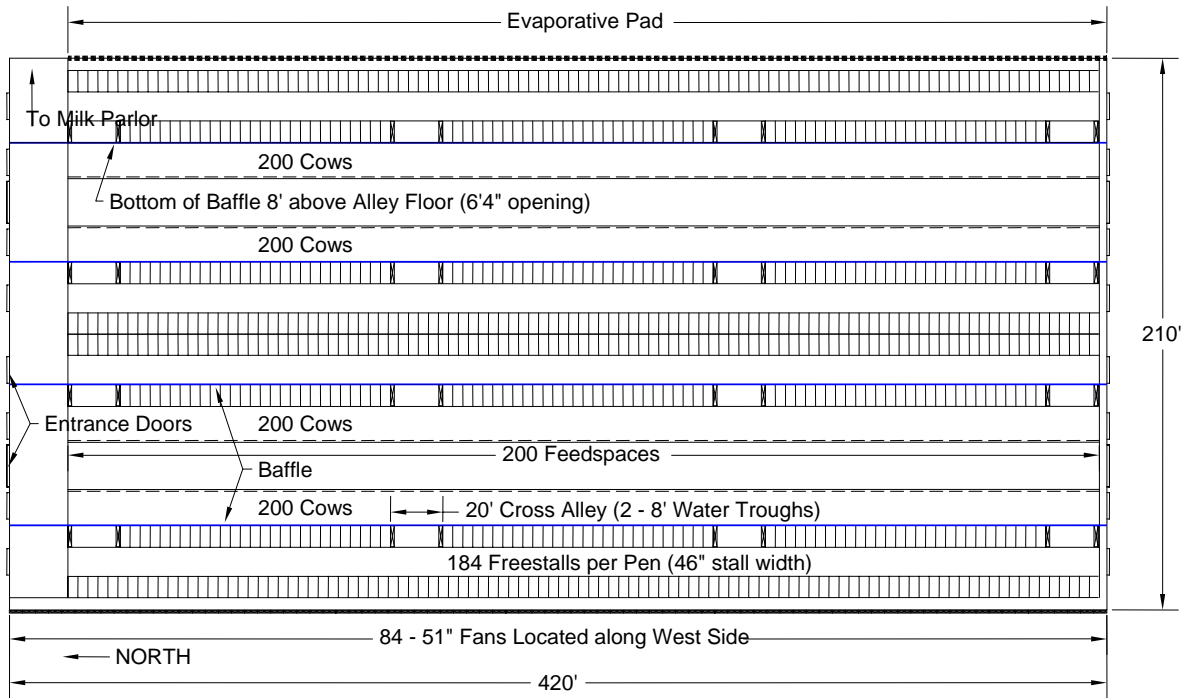




**Figure 1. Comparison of the End Views of 8-row Freestalls in Naturally Ventilated Freestalls and 8-row, Low-profile, Cross-ventilated Freestall Building.**



**Figure 2. End View of an 8-row Low-profile Cross-ventilated Freestall Building.**



**Figure 3. Top View of a Typical Layout of an 8-row Low-profile Cross-ventilated Freestall Building.** The building length is adjustable on the basis of cow numbers.

*Dairy Research 2006*

## INFLUENCE OF FACILITIES ON COW TIME BUDGETS

*J. P. Harner<sup>1</sup>, J. F. Smith, and M. J. Brouk*

### Summary

A model was developed to evaluate the impact of facilities on cow time budgets. The model suggests that in inadequate facilities overcrowding of the facility by 25% or more resulted because occupancy rate exceeded 100%. The model also is useful in evaluating the impact of time at milking center and milking frequency on cow time budget. In general, the first groups of cows through the milking parlor will have adequate time for resting, feeding, socializing, and watering. The last groups of cows through the parlor, however, do not have adequate time for these activities if the time at the milking center at each milking is 2 or more hours. Reducing time at the milking center is critical when milking 3 times daily to ensure that the last groups of cows through the parlor have adequate time for normal behavioral activities once back in the housing area.

(Key Words: Facilities, Feedline, Freestalls, Time.)

### Introduction

Daily activities of a dairy cow may be subdivided into feeding, resting, drinking, socializing, and milking. Research shows that a cow allocates, or budgets, a certain amount of time to accomplish these daily tasks, except for milking. Dairy managers or milkers control the time a cow is away from its housing area by the duration of milking procedures and

by milking parlor characteristics. Factors that influence the time away from the housing area include parlor throughput, travel distance to and from the parlor, group size, milking routine, and herd health activities. Published research indicates that cows spend approximately 5 hr for feeding, 3 hr for socializing, and 0.5 hr for drinking. The rest of the time in the housing area is for resting, with 12 hr being the minimum. These time allocations suggest that cows need at least 20.5 hr per day in the housing area. It seems that cows usually will reduce their resting time before changing their drinking, socializing, and feeding behavior patterns.

The purpose of this study was to develop procedures to evaluate the potential impact of facilities on time allocations for feeding and resting in smaller dairies. The impact of time away from the feeding and resting area also was evaluated.

### Procedures

Facilities were evaluated by using the daily percentage occupancy of the feedline and freestalls necessary to meet the baseline requirements for feeding and resting. Feedline occupancy equals:

$$\text{FLO} = (\text{C} \times \text{FT}) / (\text{FS} \times \text{PT}) \times 100$$

where FLO is the average feedline occupancy per day (%), C is number of cows, FT is desired daily feeding time per cow (hr), FS is the

---

<sup>1</sup>Department of Biological and Agricultural Engineering.

number of 24-inch feed spaces available, and PT is the time per day the cows are in the pen (hr).

Feedline occupancy represents the average percentage of the feeding spaces that must be occupied while the cows are in the pen. Pen occupancy time excludes the time cows are traveling to and from the milking parlor or at the milking center. Freestall occupancy equals:

$$\text{FSO} = (\text{C} \times \text{RT}) / (\text{ST} \times \text{PT}) \times 100$$

where FSO is the average feedline occupancy per day (%), C is number of cows, RT is desired daily resting time per cow (hr), ST is the number of freestalls in the pen, and PT is the time per day the cows are in the pen (hr).

Freestall occupancy represents the percentage of the feed stalls that must be occupied during the pen occupancy time for each cow to meet its minimum desired resting time per day.

Knowing the percentage occupancy of freestalls and feedlines provides a means to evaluate the facilities on the basis of a facility occupancy rate defined as:

$$\text{FO} = \text{FSO} + \text{FLO}$$

where FO is the facility occupancy rate (%).

If facility occupancy rate exceeds 100%, then adequate time is not available for cows to exhibit natural behavior. Cows ideally should have an opportunity to reach the desired daily feeding or resting time. This factor assumes that certain cows will use freestalls or feedline spaces even when a greater percentage of the pen is involved in other normal activities. Optimum design results in a facility occupancy rate  $\leq 85\%$ . This occupancy rate allows the cow 3.5 hr per day for water consumption and social activities in the pen, along with 12 hr of rest and 5 hr for feed consumption. A facility

occupancy rate of 85% or less indicates that there is at least one freestall and feed space per cow. If the facility occupancy rate is between 85 and 100%, then the pen is overstocked, but the facilities do not hinder the cow's normal behavior. Once the facility occupancy rate exceeds 100%, some cows must choose between feeding or resting because there are inadequate facilities and time to meet the targeted time budget.

## Results and Discussion

Table 1 shows the potential impact of milking times on facility occupancy rate for a 100-cow dairy, assuming no overstocking of the feedline or freestalls. The dairy was assumed to be milking twice daily, and parlor capacity was evaluated based on milking 100, 50, and 33 cows per hr, or 1, 2, and 3 hr per milk shifts.

Table 1 indicates that, on average, the facilities are not a limiting factor because the facility occupancy rate is  $< 100\%$ . Research suggests, however, that 20.5 hr in the housing area is the minimum time required for a cow to socialize, rest, and feed. Table 1 shows that when facilities are not overstocked, the freestalls will only be occupied an average of 60 to 70% of the time, even with the longer milking times.

Cows in the milking center more than 3.5 hr daily may not have adequate time for normal activities. To evaluate the impact of time at the milk center, cow-time budgets for the first group through the parlor and last group through the parlor were evaluated. Table 2 shows the impact of the milking shift on resting time available for those cows milked near the beginning and end of the milking shift for a 100-cow dairy example shown in Table 1.

Facilities potentially enable the first cows through the parlor to rest for 15 hr per day, compared with a target of 12 hr. The last cows through the parlor obtain the targeted 12 hr of

rest per day if the group is milked in 1 hr or less. The latter groups do not receive adequate resting time if they are at the parlor 2 or more hr per shift. Cows moving through the parlor during the first half of the milking shift have adequate time to meet normal their behavior activity.

Table 3 shows the impact of overcrowding a dairy facility, assuming the current herd size is 100 cows. If a 67-cow facility is overcrowded by 50% (100 lactating cows), the facility occupancy rate equals 132%. To ensure adequate resting time, 93% of the freestalls must be occupied all the time that cows are not at the milking center. In addition, 39% of the feeding spaces must be occupied. Once the facility occupancy rate exceeds 100%, then some cows must choose between feeding or resting because inadequate facilities and time exist to meet the targeted cow-time budget. Reducing time at the milking center from 120 to 60 minutes per milk shift decreases the facility occupancy rate from 110 to 100%. Thus, reducing the time at the milking center by 60 minutes per milk shift provides the minimum time for resting and feed-

ing, even if the facility is overcrowded by 25%. Facilities are still inadequate, even if the time at the milking center is reduced, when a dairy opts to overcrowd facilities by 50%.

Table 4 shows the impact of milking twice or 3 times daily. Milking 3 times daily does not impact the resting of the first cows through parlor. The resting time of the last cows through the parlor is influenced by milking interval, time at the milking center, and overcrowding. The model suggests that the time at the milking center must be reduced to less than 1 hr when milking 3 times daily, because occupancy rate exceeds 100%. The last cows through the parlor only have 8.5 hr of resting available per day when milking occurs 3 times daily and time at the milk center is 2 hr.

Facility occupancy rates provide a methodology for evaluating the influence of feedline space and freestalls on the time budget of cows. Milking frequency and time away from the housing area have an influence on available time for resting and feeding.

**Table 1. Facility Occupancy Rate Based on Time at the Milking Center for Each Milking**

Time at Milking Center per Milking, min	Travel Time To and From the Parlor, min	Freestall Occupancy Rate, %	Freestall Occupancy Rate, %	Facility Occupancy Rate, %
60	10	56	23	80
120	10	62	26	88
180	10	69	29	98

**Table 2. Influence of Time at the Milking Center on the Resting Time of Cows Milked First and Last in the Parlor**

Time at Milking Center, min	Travel Time		First Cows Through Parlor, hr	Last Cows Through Parlor, hr
	To and From Milking Parlor, min			
60	10		15	12.8
120	10		15	10.8
180	10		15	8.8

**Table 3. Influence of Overcrowding Facilities and Time at the Milking Center on Facility Occupancy Rate**

Time at Milking Center, min	Percentage Overcrowding of Facilities	Freestall Occupancy Rate, %	Feedline Occupancy Rate, %	Facility Occupancy Rate, %
120	0	62	26	88
120	25	78	32	110
120	50	93	39	132
60	25	70	30	100
60	50	84	36	120

**Table 4. Influence of Milking Frequency on Facility Occupancy Rate and Resting Time**

Time at Milking Center, min	Daily Milking Frequency, no. of times	Number of Stalls per Pen	Percentage Overcrowding of Facilities	Facility Occupancy Rate, %	Available Resting Time, hr	
					First Cows Through Parlor	Last Cows Through Parlor
120	3	100	0	100	13.1	8.5
120	3	80	25	125	13.1	8.5
120	2	100	0	80	13.9	10.8
120	2	80	25	110	13.9	10.8
60	3	100	0	85	14.1	11.5
60	3	80	25	106	14.1	11.5
60	3	100	0	85	14.6	12.8
60	2	80	25	100	14.6	12.8

*Dairy Research 2006*

**INDEX OF KEY WORDS**

Indexer's note: The numbers indicate the first pages of each article that uses the listed key word.

Availability (6)	Nutrient Management (12)
Body Temperature (38)	Nutrition (14)
By-products (14)	Ovsynch (18, 22)
CIDR (26)	Ovulation (18, 22, 32)
Cooling (38)	Packaging Size (34)
Cooling Systems (44, 49)	Phosphorus (12)
Cross Ventilation (49)	Pregnancy Rate (18, 22, 26)
Evaporative Cooling (44)	Protein (1, 6)
Facilities (52)	Soybean Meal (1, 6)
Follicle (18)	Temperature Cycling (34)
GnRH (26, 32)	Water Usage (44)
hCG (26, 32)	Wet Corn Milling (14)
Heat Stress (38)	Feedline (52)
Luteolysis (22)	Freestalls (52)
Milk Flavor (34)	Time (52)

*Dairy Research 2006*

**ACKNOWLEDGMENTS**

Appreciation is expressed to the following organizations for their support of dairy teaching, research, and extension at Kansas State University during 2005-2006:

Acadian Agritech, Dartmouth, Nova Scotia, Canada	Kansas Artificial Breeding Service Unit (KABSU), Manhattan, KS
Adisseo, Alpharetta, GA	Kansas Dairy Commission, Wamego, KS
Cargill, Inc. Blair, NE	Kansas Farm Management Association, Manhattan, KS
Cimarron Dairy, Cimarron, KS	Kansas Health and Environment, Topeka, KS
Consolidated Container Company, Minneapolis, MN	Linn Willow Creek Dairy, Linn, KS
Dekalb Asgrow, St. Louis, MO	Meier Dairy of Palmer, Inc., Palmer, KS
Elanco Animal Health, Greenfield, IN	Merial Limited, Iselin, NJ
Environmental Health Protection Agency, Washington, D.C.	Monsanto Company, St. Louis, MO
Fort Dodge Animal Health, Fort Dodge, IA	National Association of Animal Breeders, Columbia, MO
Felton International, Lenexa, KS	Ohlde's Dairy, Linn, KS
Grain State Soya, West Point, NE	Pfizer Animal Health, New York, NY
Heart of America Dairy Herd Improvement Association (DHIA), Manhattan, KS	Pioneer Hi-Bred International, Inc., Des Moines, IA
Hubbard Feed, Mankato, MN	Rota-Mix, Dodge City, KS
Intervet, Inc., Millsboro, DE	Select Sires, Plain City, OH
Iowa Limestone, Des Moines, IA	Shenandoah, Dairy, Live Oak, FL
IVX Animal Health, St. Joseph, MO	Western Dairy Management Conference
Kansas Agricultural Experiment Station, Manhattan, KS	York's Dairy, Cuba City, WI
	Zinpro Corp., Eden Prairie, WI

Appreciation is expressed to Valerie Stillwell and Charlotte Bruna for typing the contents of this publication. The Departments of Agricultural Economics and Biological and Agricultural Engineering of the College of Agriculture at Kansas State University are recognized for their cooperation and contribution to our dairy research program.

Contribution No. 07-118-S, from the Kansas Agricultural Experiment Station, Kansas State University, Manhattan 66506. Trade names are used to identify products. No endorsement is intended, nor is any criticism implied of similar products not named.

*Dairy Research 2006*

## **BIOLOGICAL VARIABILITY AND CHANCES OF ERROR**

Variability among individual animals in an experiment leads to problems in interpreting the results. Although the cattle on treatment X may have produced more milk than those on treatment Y, variability within treatments may indicate that the differences in production between X and Y were not the result of the treatment alone. Statistical analysis allows us to calculate the probability that such differences are from treatment rather than from chance.

In some of the articles herein, you will see the notation " $P < .05$ ". That means the probability of the differences resulting from chance is less than 5%. If two averages are said to be "significantly different," the probability is less than 5% that the difference is from chance, or the probability exceeds 95% that the difference resulted from the treatment applied.

Some papers report correlations or measures of the relationship between traits. The relationship may be positive (both traits tend to get larger or smaller together) or negative (as one trait gets larger, the other gets smaller). A perfect correlation is one (+1 or -1). If there is no relationship, the correlation is zero.

In other papers, you may see an average given as  $2.5 \pm .1$ . The 2.5 is the average; .1 is the "standard error." The standard error is calculated to be 68% certain that the real average (with an unlimited number of animals) would fall within one standard error from the average, in this case between 2.4 and 2.6.

Using many animals per treatment, replicating treatments several times, and using uniform animals increase the probability of finding real differences when they exist. Statistical analysis allows more valid interpretation of the results, regardless of the number of animals. In all the research reported herein, statistical analyses are included to increase the confidence you can place in the results.

***Contents of this publication may be freely reproduced for educational purposes. All other rights reserved. In each case, give credit to the author(s), name of work, Kansas State University, and the date the work was published.***



## **The Livestock and Meat Industry Council, Inc.**

The Livestock and Meat Industry Council, Inc. (LMIC) is a non-profit charitable organization supporting animal agriculture research, teaching, and education. This is accomplished through the support of individuals and businesses that make LMIC a part of their charitable giving.

Tax-deductible contributions can be made through gifts of cash, appreciated securities, real estate, life insurance, charitable remainder trusts, bequests, as well as many other forms of planned giving. LMIC can also receive gifts of livestock, machinery, or equipment. These types of gifts, known as gifts-in-kind, allow the donor to be eligible for a tax benefit based on the appraised value of the gift.

Since its inception in 1970, LMIC has provided student scholarships, research assistance, capital improvements, land, buildings, and equipment to support students, faculty, and the industry of animal agriculture. If you would like to be a part of this mission or would like additional information, please contact the Livestock and Meat Industry Council/Animal Sciences and Industry, Weber Hall, Manhattan, Kansas 66506 or call 785-532-1244.

### **LMIC Board Members:**

Raymond Adams, Jr	Sam Hands	Gina Miller
Dell Allen	Bernie Hansen	Andrew Murphy
Jerry Bohn	Greg Henderson	Tom Perrier
Max Deets	Steven Hunt	Phil Phar
Galen Fink	Steve Irsik	Lee Reeve
Randy Fisher	Dan Johnson	Ken Stielow
Henry Gardiner	Larry Jones	Mikel Stout
Craig Good	Pat Koons	Duane Walker
Lyle Gray	Jan Lyons	Warren Weibert

### **Royal Board Members:**

Bill Amstein	Stan Fansher	Harland Priddle
Richard Chase	Fred Germann	Don Smith
Calvin Drake	Don Good	

### **Auxiliary Board Members:**

Fred Cholick	Janice Swanson
Aaron Hund	Joe Downey

## DAIRY RESEARCH 2006

---

This publication is produced by the Department of Communications at Kansas State University. This publication is available via the World Wide Web at:

*<http://www.oznet.ksu.edu/library> [type Dairy Research in the search box].*

Copyright 2006 Kansas State University Agricultural Experiment Station and Cooperative Extension Service. Contents may be freely reproduced for educational purposes. All other rights reserved. In each case, give credit to the author(s), Dairy Research 2006, Kansas State University, December 2006.