

# Kansas Agricultural Experiment Station Research Reports

---

Volume 0  
Issue 2 *Dairy Research (1984-2014)*

Article 393

---

2010

## Dairy Research 2010

Kansas Agricultural Experiment Station

Follow this and additional works at: <https://newprairiepress.org/kaesrr>

---

### Recommended Citation

Kansas Agricultural Experiment Station (2010) "Dairy Research 2010," *Kansas Agricultural Experiment Station Research Reports*: Vol. 0: Iss. 2. <https://doi.org/10.4148/2378-5977.7170>

This report is brought to you for free and open access by New Prairie Press. It has been accepted for inclusion in Kansas Agricultural Experiment Station Research Reports by an authorized administrator of New Prairie Press. Copyright 2010 the Author(s). Contents of this publication may be freely reproduced for educational purposes. All other rights reserved. Brand names appearing in this publication are for product identification purposes only. No endorsement is intended, nor is criticism implied of similar products not mentioned. K-State Research and Extension is an equal opportunity provider and employer.



# DAIRY RESEARCH 2010

REPORT OF PROGRESS 1039



KANSAS STATE UNIVERSITY  
AGRICULTURAL EXPERIMENT  
STATION AND COOPERATIVE  
EXTENSION SERVICE





# DAIRY RESEARCH 2010

## Contents

- II Foreword
- IV Biological Variability and Chances of Error

### *Nutrition and Feeding*

- 1 Effects of Wet Corn Gluten Feed and Dietary Particle Size on Ruminal Fermentation and Milk Production
- 5 Effects of Varying Rates of Tallgrass Prairie Hay and Wet Corn Gluten Feed on Productivity of Dairy Cows
- 12 Lysine Degradation by Ruminal *Fusobacterium necrophorum*
- 16 Bioavailability of Lysine from Hydroxymethyl Lysine
- 19 Effects of Continuous Infusion of Tumor Necrosis Factor-Alpha into Adipose Tissue on Glucose and Fatty Acid Metabolism in Lactating Dairy Cattle

### *Reproduction*

- 22 Ovarian Characteristics, Serum Hormone Concentrations, and Fertility in Lactating Dairy Cows in Response to Equine Chorionic Gonadotropin
- 27 Acknowledgments
- 28 The Livestock and Meat Industry Council, Inc.

# DAIRY RESEARCH 2010

## Foreword

Members of the Dairy Team at Kansas State University are pleased to present the 2010 Dairy Research Report of Progress. Dairying continues to contribute significantly to the agricultural economy of Kansas. In 2009, dairy farms accounted for 2.9%, or \$347 million, of all Kansas farm receipts, ranking 7th overall among all Kansas farm commodities. In the United States, Kansas had the greatest percentage increase in milk produced between 1999 and 2004 (+57.7%). At the end of 2009, Kansas ranked 9th nationally in milk yield per cow at 21,085 lb, 17th in the number of dairy cows (118,000), and 16th in total milk production (2.488 billion lb). Wide variation exists in the productivity per cow as indicated by the Heart of America Dairy Herd Improvement Association (DHIA) production testing program. At the end of 2009, 100,768 cows were enrolled in the DHI program from Kansas, Nebraska, Oklahoma, Arkansas, North Dakota, and South Dakota, including herds from Colorado (2), Missouri (8), and Texas (1). A comparison of all Kansas DHIA cows and those at the Kansas State University Dairy Teaching and Research Center (DTRC) with those in the Heart of America DHIA program for 2009 is shown in the following table.

**Comparison of Heart of America (HOA) Cows with Kansas Cows and Kansas State University Cows - 2009**

Item	HOA	KS	DTRC <sup>1</sup>
Herds, no.	517	180	...
Cows/herd, no.	196	117	249
Milk, lb	20,934	21,397	29,587
Fat, lb	775	792	987
Protein, lb	670	667	907
Somatic cell count x 1,000	270	309	158
Calving interval, mo	14.0	14.2	13.2

<sup>1</sup> October 12, 2010 test day (milking 3 times daily; no bovine somatotropin).

Most of this success occurs because dairy producers better manage what is measured in monthly DHI records. Continued emphasis should be placed on furthering the DHI program and encouraging use of its records in making management decisions. In addition, continued use of superior, proven sires and emphasis on use of superior genetics in artificial insemination programs is essential.

The excellent functioning of the DTRC is because of special dedication of our staff. We acknowledge our current DTRC staff for their dedication: Michael V. Scheffel (manager), Michelle L. Sullivan, John P. Dwyer, Daniel J. Umsheid, Alan J. Hubbard, and Kris Frey. Special thanks are given to Colleen Hill, Cheryl K. Armendariz, and a host of graduate and undergraduate students for their technical assistance in our laboratories and at the DTRC. We also

acknowledge the support and cooperation of David Sukup and the DHIA laboratory here in Manhattan, KS, for their assistance in handling research milk samples.

Thorough, quality research is not only time intensive and meticulous, but also expensive. Each dollar spent for research yields a 30 to 50% return in practical application. Those interested in supporting dairy research are encouraged to consider participation in the Livestock and Meat Industry Council (LMIC), a philanthropic organization dedicated to furthering academic and research pursuits by the Department of Animal Sciences and Industry. Additional details about the LMIC are found at the end of this report.

J. S. Stevenson, Editor  
2010 Dairy Research Report of Progress

## Biological Variability and Chances of Error

Variability among individual animals in an experiment leads to problems in interpreting the results. Although the cattle on treatment X may have produced more milk than those on treatment Y, variability within treatments may indicate that the differences in production between X and Y were not the direct result of the treatment alone. Statistical analysis allows us to calculate the probability that such differences occur because of the treatment applied rather than from chance.

In some of the articles herein, you will see the notation  $P < 0.05$ . That means the probability of treatment differences resulting from chance is less than 5%. If two averages are reported to be significantly different, the probability is less than 5% that the difference is from chance, or the probability exceeds 95% that the difference resulted from the treatment applied.

Some papers report correlations or measures of the relationship between traits. The relationship may be positive (both traits tend to get larger or smaller together) or negative (as one trait gets larger, the other gets smaller). A perfect correlation is one (+1 or -1). If no relationship exists, the correlation is zero.

In other papers, you may see an average given as  $2.5 \pm 0.1$ . The 2.5 is the average; 0.1 is the standard error. The standard error is calculated to be 68% certain that the real average (with an unlimited number of animals) would fall within one standard error from the average, in this case between 2.4 and 2.6.

Using many animals per treatment, replicating treatments several times, and using uniform animals increase the probability of finding real differences when they exist. Statistical analysis allows more valid interpretation of the results, regardless of the number of animals in the experiment. In all the research reported herein, statistical analyses are included to increase the confidence you can place in the results.

# Effects of Wet Corn Gluten Feed and Dietary Particle Size on Ruminal Fermentation and Milk Production

*M. L. Sullivan and B. J. Bradford*

## Summary

Wet corn gluten feed (WCGF) was included in 4 diets at 0, 11, 23, and 34% of diet dry matter. Alfalfa hay was used to maintain at least 10% of particles  $\geq 0.71$  inches in length (the top screen of the Penn State Particle Separator) in all diets. Ruminal probes were placed in the rumens of 7 ruminally cannulated lactating Holstein dairy cows to measure ruminal pH. As WCGF increased in the diet, dry matter intake and milk production increased quadratically with 23% WCGF supporting the highest feed intake and milk yield. Ruminal pH and milk fat content were similar across all diets.

**Key words:** alfalfa, dry matter intake, milk yield, wet corn gluten feed

## Introduction

As the competition for corn grows, dairy producers continue to look for alternative approaches to feeding cows while maintaining animal performance, health, and profitability. One option is the inclusion of wet corn gluten feed (WCGF) in the ration. The energy provided by WCGF is comparable with that of corn, making it a viable substitute in a lactating cow diet.

Many studies have been conducted to investigate responses to WCGF in lactating cow rations. Most dairy cattle studies have focused on the effects of replacing corn grain, corn silage, and alfalfa hay with WCGF, which can potentially reduce ruminal pH (Mullins et. al., Dairy Research 2009, Report of Progress 1021, pp. 34-40). The previous work showed that as feed intake increased, milk production also increased, whereas ruminal pH declined. One reason for this response could have been the small particle size of the diets in that study; small particle size limits salivary buffer secretion as well as rumen fill. No studies have been performed looking directly at the effects of feeding WCGF while maintaining a minimum particle size in lactation diets.

The objective of this study was to investigate the impacts of WCGF (0, 11, 23, and 34% of diet dry matter) on ruminal pH, feed intake, and milk production while maintaining particle size of the diets. We hypothesized that by maintaining at least 10% of particles  $\geq 0.71$  inches in length, ruminal pH would be consistent across all diets, whereas feed intake and milk production would increase as WCGF inclusion rate increased.

## Experimental Procedures

Four multiparous and 3 primiparous ruminally cannulated, lactating Holstein cows were assigned randomly to 1 of 4 diets in an incomplete  $4 \times 4$  Latin square design to evaluate the effects of WCGF on feed intake, productivity, and ruminal pH. One cow was removed from the study after the completion of the second period because of unrelated health problems. The study consisted of 4 periods, each lasting 21 days with 17 days of adaptation and 4 days for sample collection. Diets included WCGF at 0, 11, 23, or 34% of diet dry matter and were formulated and mixed to have at least 10% of particles  $\geq 0.71$  inches. The purpose of fixing the particle size was to maintain adequate effective neutral detergent fiber (eNDF) in the diet. Particle size goals were achieved by grinding alfalfa for 2 minutes in a horizontal mixing wagon



(Roto-mix, Dodge City, KS). The formulations of the 4 diets, which were identical to those used in the 2009 study, are shown in Table 1. Cows were fed twice daily at 11:00 a.m. and 3:00 p.m. and milked thrice daily at 2:00 a.m., 10:00 a.m., and 6:00 p.m. Animals were housed in a tie stall barn with an evaporative cooling system from June to August 2010 at the Kansas State University Dairy Teaching and Research Center.

On days 18 to 21 of each period, components and yields of milk were collected at each milking. Ruminal fluid and fecal samples were collected every 8 hours from days 18 to 20. Free-floating ruminal pH probes were calibrated and inserted into the rumen through the cannula, and ruminal pH was recorded every 5 minutes on days 17 to 20. Feed and water intake were recorded daily during the sampling period and feed ingredients, total mixed rations, and feed refusals were collected for analyses.

## Results and Discussion

Intake and milk component responses are presented in Table 2. A quadratic effect ( $P = 0.02$ ) on dry matter intake was detected, with the greatest intake for the 23% WCGF diets. Milk production responded in quadratic fashion ( $P = 0.02$ ), with the 23% WCGF diet again yielding the greatest response. No differences were detected among diets for 3.5% fat-corrected milk yield, body condition score change, or body weight change. In contrast, energy-corrected milk yield tended to increase linearly as WCGF was added to the diet.

Milk fat content, lactose content, and milk fat yield did not differ among diets (Table 3). Milk protein yield increased linearly ( $P < 0.01$ ) with WCGF inclusion, whereas milk lactose yield and milk urea nitrogen (MUN) concentration both increased quadratically. The quadratic increase in milk lactose yield was a result of the increase in milk production, because no differences in lactose content were observed among diets.

The study was designed to maintain eNDF across all diets by utilizing alfalfa hay to achieve consistency in particle size between diets. This may help to explain the similarity in mean and variation of ruminal pH across diets (Table 4). Although ruminal pH was lower than desirable, cows did not meet the standard criteria for diagnosis of sub-acute ruminal acidosis at any point during the study. Neither time under nor area under pH 5.8 or pH 5.6 were affected by treatment.

When dietary inclusion of WCGF was increased to 23% of the dry matter while maintaining a minimum dietary particle size, dry matter intake, milk yield, and protein yield were increased and ruminal pH was maintained. The quadratic increase observed in this study indicates that including WCGF at 23% of diet dry matter results in the greatest production response for the types of diets fed in this study.

NUTRITION AND FEEDING

**Table 1. Ingredient and nutrient composition (% of dry matter) of dietary treatments containing increasing amounts of wet corn gluten feed (WCGF)**

Item	Dietary WCGF			
	0%	11%	23%	34%
Ingredient, % of dry matter				
Corn silage	25.2	25.5	22.1	18.4
WCGF	--	11.4	23.2	33.6
Alfalfa	24.4	24.6	21.2	17.7
Cottonseed	6.1	6.2	6.2	6.1
Corn grain	23.5	19.9	17.3	14.6
Soybean meal 48	8.6	4.9	2.2	2.2
Molasses	0.4	0.4	0.4	0.4
Soybean hulls	5.0	---	---	---
Limestone	1.0	1.08	1.28	1.36
Expeller soybean meal	3.3	3.7	4.0	3.6
Magnesium oxide	0.26	0.24	0.21	0.17
Micronutrient premix	1.33	1.32	1.33	1.31
Nutrient				
Dry matter, % as-fed	65.4	60	61.3	61.2
Crude protein	19.3	18.8	19.1	20.1
Neutral detergent fiber	28.8	28.8	30.4	31.0
Starch	24.3	27.9	25.5	24.2
Non-fiber carbohydrate	39.1	40.9	38.6	37.6
Ether extract	3.4	3.3	3.6	3.6
Ash	9.4	8.3	8.3	7.7

NUTRITION AND FEEDING

**Table 2. Effects of dietary wet corn gluten feed (WCGF) on intake and performance of lactating cows**

	Dietary WCGF <sup>1</sup>				SEM	P value	
	0%	11%	23%	34%		Linear	Quadratic
Dry matter intake (DMI), lb/day	55.6	58.7	59.5	58.4	2.6	0.02	0.02
Water intake, gal/day	34.1	34.1	37.1	36.7	2.1	0.11	0.88
Milk, lb/day	83.1	90.0	91.3	89.7	8.0	0.01	0.02
3.5% fat-corrected milk, lb/day	76.7	82.2	80.9	81.1	6.7	0.19	0.18
Energy-corrected milk (ECM), lb/day	77.8	83.6	82.9	83.1	6.7	0.08	0.14
ECM/DMI	1.39	1.43	1.39	1.42	0.08	0.60	0.92
Body weight change, lb/21 days	-5.9	-24.5	-30.3	-13.9	19.4	0.58	0.14
Body condition score change/21 days	-0.10	-0.05	-0.08	0.03	0.052	0.14	0.56

<sup>1</sup> Inclusion rate of WCGF on a dry matter basis.

**Table 3. Effects of dietary wet corn gluten feed (WCGF) on milk components**

	Dietary WCGF <sup>1</sup>				SEM	P value	
	0%	11%	23%	34%		Linear	Quadratic
Milk fat, %	3.05	2.99	2.83	2.97	0.16	0.24	0.17
Milk protein, %	2.94	2.92	2.93	3.01	0.12	0.10	0.09
Lactose, %	4.84	4.87	4.86	4.84	0.07	0.93	0.29
Milk urea nitrogen, mg/dL	13.2	12.6	12.9	13.6	0.82	0.30	0.04
Yield, lb/day							
Milk fat	2.51	2.67	2.56	2.60	0.24	0.73	0.53
Milk protein	2.40	2.60	2.65	2.67	0.20	< 0.01	0.09
Milk lactose	4.01	4.37	4.39	4.32	0.35	0.03	0.02

<sup>1</sup> Inclusion rate of WCGF on a dry matter basis.

**Table 4. Effects of dietary wet corn gluten feed (WCGF) on rumen pH**

pH response	Dietary WCGF <sup>1</sup>				SEM	P value	
	0%	11%	23%	34%		Linear	Quadratic
Mean	6.05	6.13	6.00	6.00	0.07	0.26	0.45
Standard deviation	0.42	0.40	0.40	0.44	0.02	0.58	0.19
Time under 5.8 (min/day)	434	304	467	465	72.9	0.31	0.24
Area under 5.8 (pH x min/day)	130	87.6	144	138	28.5	0.50	0.46
Time under 5.6 (min/day)	257	175	290	293	56.4	0.33	0.39
Area under 5.6 (pH x min/day)	61.6	39.2	73.2	61.1	16.6	0.65	0.74

<sup>1</sup> Inclusion rate of WCGF on a dry matter basis.

# Effects of Varying Rates of Tallgrass Prairie Hay and Wet Corn Gluten Feed on Productivity of Dairy Cows

*D.J. Rezac, K.N. Grigsby<sup>1</sup>, and B.J. Bradford*

## Summary

Productivity of lactating dairy cows was assessed when fed diets containing wet corn gluten feed (**WCGF**; Sweet Bran, Cargill Inc.) as the primary energy substrate and prairie hay as the primary source of physically effective neutral detergent fiber (**peNDF**) compared with a control diet. Treatment diets were: 1) a control diet with 18% alfalfa, 18% corn silage, 33% WCGF, and 15% forage NDF (**CON**); 2) a diet with 20% tallgrass prairie hay, 46% WCGF, and 13% forage NDF (**TPH20**); and 3) a diet with 14% tallgrass prairie hay, 56% WCGF, and 9% forage NDF (**TPH14**). Midway through period 2, the TPH14 treatment diet was discontinued because of numerous cases of diarrhea. Dry matter intake was not altered by treatment. Milk yields were 80.0, 76.3, and 78.5 lb/day for CON, TPH20 and TPH14, respectively; milk yield was greater for CON than TPH20. Milk fat percentage was least for TPH14 with means of 3.47, 3.40, and 2.82% for CON, TPH20, and TPH14, respectively. Fat yield was greater for CON compared with TPH14, but was not different from TPH20. Milk urea nitrogen (MUN) was greatest for TPH20 and least for CON with TPH14 being intermediate, consistent with differences in dietary protein. Efficiencies, expressed as energy corrected milk divided by dry matter intake, were 1.45, 1.40, and 1.30 for CON, TPH20, and TPH14, respectively, and did not differ among diets. These data indicate that TPH14 did not provide adequate peNDF to support normal rumen function in midlactation dairy cows; however, TPH20 offered a feasible diet for use in dairies where high-NDF grass hay and WCGF are available.

**Key words:** milk yield, tall grass prairie hay, wet corn gluten feed

## Introduction

Poor milk prices or small profit margins lead dairy producers to search for opportunities to reduce input costs. Often the first area of interest is feed cost, because this often represents the largest variable cost for dairy operations. Novel diet formulation methods using atypical feedstuffs or uncommon inclusion rates may be a way to decrease ration costs. In addition, in circumstances in which supplies of typical feedstuffs may not be sufficient for a production year, a ration that includes alternative feed ingredients may be useful when those ingredients are readily available and do not severely compromise performance.

Wet corn gluten feed (**WCGF**), a coproduct of the wet-milling process, is a high-fiber, low-lignin feedstuff that has been shown to be a viable optional component in lactating dairy cattle rations. Although the fiber in WCGF is highly digestible, the effective neutral detergent fiber (NDF) percentage can be variable depending on the method used to estimate it. Estimations of the effective NDF (**eNDF**) percentage in WCGF have ranged from 32.9% to just 5.7% based on change in milk fat concentration and ruminal pH, respectively, whereas physically effective NDF (**peNDF**) has been estimated to be 4.8%, based solely on rumination activity. Regardless of the variance of these figures, peNDF must be supplied by other fiber sources to prevent ruminal acidosis and milk fat depression. WCGF, because of the nature of its origin, is quite low in rapidly fermentable carbohydrates such as starch compared with other high-energy feedstuffs,

<sup>1</sup> Cargill, Inc., Blair, NE.

so the risk of ruminal acidosis is decreased. Taking this into account, a diet with high inclusion rates of WCGF may be formulated with lower peNDF.

Tallgrass prairie hay (TPH), a mixture of many grass species native to the central plains region, is a relatively inexpensive forage fiber source that is typically fed to beef cattle or far-off dry dairy cows with a low energy requirement. On average, TPH consists of about 67.4% NDF, 15.2% acetyl bromide lignin, and 3.9% crude protein, and thus, depending on processing, TPH may be used as a good source of peNDF in a ration. The nature of TPH and WCGF may complement each other in lactating dairy cow rations. No published research, however, has shown the effects of such a diet compared with a ration containing common ingredients such as alfalfa hay and corn silage. Our objectives were to compare diets containing varying amounts of TPH and WCGF with a control ration and observe effects on productivity of lactating dairy cows.

## Experimental Procedures

Twenty-one primiparous and 27 multiparous lactating Holstein cows ( $167 \pm 47$  days in milk,  $1.8 \pm 0.97$  lactations, mean  $\pm$  SD) were selected from the Kansas State University Dairy Teaching and Research Center herd and assigned randomly to 1 of 6 free-stall pens. Pens were assigned to a treatment sequence in a replicated  $3 \times 3$  Latin square design that was balanced for carryover effect of treatment. Treatment periods were 21 days, with 17 days of diet adaptation and 4 days of sampling. Feeding of treatment diets began in September and continued through November 2009. Cows were fed daily a fresh total mixed ration (TMR) blended in a TMR wagon at 9:30 a.m. and milked 3 times daily at 6:00 a.m., 1:00 p.m., and 8:00 p.m.

Three treatment diets consisted of: 1) a control (CON) diet containing 18% of dry matter alfalfa hay and 18% of dry matter corn silage; 2) a diet containing 20% of dry matter TPH (TPH20); and 3) a diet containing 14% of dry matter TPH (TPH14; Table 1). Rations were formulated to contain similar protein and energy concentrations with varying amounts and sources of forage NDF; however, chemical analysis showed that protein concentration was not constant among rations.

Midway through period 2, feeding of TPH14 was discontinued because of diarrhea in more than 25% of cows fed that diet. The 2 pens on TPH14 then were switched to the CON ration for the remainder of period 2 and pens allocated to TPH14 in period 3 were assigned to either TPH20 or CON.

Feed offered and refusals for each pen were recorded on the final 4 days of each treatment period except in the case of inclement weather. The TMR samples also were gathered on these days, composited by period, and analyzed by particle size using a 4-compartment Penn State Particle Separator. Samples of corn silage, alfalfa hay, TPH, WCGF, cottonseed, and grain mixes also were gathered for laboratory analysis. Milk samples were collected for each cow at every milking during the last 4 days of each sample period and analyzed for milk fat, protein, lactose, somatic cells, and urea nitrogen at the Heart of America Dairy Herd Improvement Association laboratory (Manhattan, KS). Body weight was measured on day 21 of each period immediately following the milking at 1:00 p.m. Data were analyzed using JMP (version 6.0, SAS Institute, Cary, NC) including the fixed effect of treatment diet, the random effect of period, and the random effect of pen. The random effects of cow nested within pen and period by pen interaction also were included in the model when analyzing milk traits.

## NUTRITION AND FEEDING

**Economic Analysis.** Prices of alfalfa hay, corn silage, dry rolled corn, soybean meal, and whole cotton seed were obtained from the Penn State Feed Price list (June 15, 2010). Price of WCGF was obtained from the University of Missouri By-Product Feed Price Listing (June 19, 2010) with freight costs added for transportation from the point of origin to the Kansas State University Dairy Teaching and Research Center in Manhattan, KS. Vitamin and mineral mix cost was fixed across both treatments at \$0.38/lb of dry matter. Ration costs were multiplied by the dry matter intakes for each respective treatment to produce actual cost per cow per day. The milk price of \$0.14/lb was multiplied by the milk yields for each respective treatment to produce income per cow per day.

## Results and Discussion

**Diet Composition and Particle Size.** Diets were formulated to be isocaloric and isonitrogenous; however, crude protein levels fluctuated among diets because of differences in nitrogen concentration of the respective grain mixes (Table 2). Milk urea nitrogen (MUN) was greater ( $P < 0.004$ ) for cows that consumed TPH20 and least for CON, 17.0 and 13.9 mg/dL, respectively. Not surprisingly, these differences coincided with the differences in dietary crude protein, but minimum target values for MUN of 10 mg/dL were met, suggesting that protein limitation of milk synthesis or components was not a factor (Table 3).

Physically effective NDF values were 15.8, 11.9, and 11.6% of diet dry matter for CON, TPH20, and TPH14, respectively, and were greater ( $P < 0.05$ ) for CON compared with TPH20 (Table 1). As described in the methods, TPH14 was discontinued midway through period 2 because of numerous cases of diarrhea and gastrointestinal tract abnormalities, which is a common result of a lack of adequate peNDF in the diet. In contrast, peNDF values for TPH20 and TPH14 were not different, suggesting that perhaps the method used to calculate peNDF for the diets was not adequate for rations of this nature.

Particles > 19.0 mm (% of dry matter) were 18.8%, 14.7%, and 9.1% for CON, TPH20, and TPH14 diets (Table 4), respectively, but did not differ from one another. Percentages of particles retained on the middle screen was greatest for CON and least for TPH20 ( $P < 0.05$ , 27.2 vs. 16.0%). Percentage of particles retained on the lower sieve was greatest ( $P < 0.05$ ) for TPH20 and least for CON.

**Dry Matter Intake and Performance.** Dry matter intakes did not differ among treatment diets (Table 5). Dry matter intake is controlled by a complex set of factors that possess the ability to outweigh each another depending on the nature of the diet being consumed. Dry matter intake of diets with greater amounts of peNDF as a result of a greater amount of large feed particles, as was the case for CON, are more likely to be limited by physical regulation mechanisms. In contrast, in the case of TPH20 and TPH14 where peNDF was lower, a significant increase in dry matter intake was not detected.

Milk yield (Table 5) was greatest for CON and least for TPH20 ( $P < 0.05$ ) with TPH14 remaining intermediate. Efficiency was not different among any treatments. Milk fat yield and percentage (Table 2) were greatest for CON and least for TPH14 ( $P < 0.05$ ); however, TPH20 was not different from CON. Ability of the diets with high inclusion rates of WCGF, but with low forage NDF and peNDF concentrations, to maintain acceptable milk fat production may likely be attributed to the lower starch content of WCGF that may limit the occurrence of ruminal acidosis, which leads to milk fat depression.

## NUTRITION AND FEEDING

Although use of milk fat to measure the effectiveness of the fiber in rations encompasses a far greater set of variables within the ration, it cannot be used to decide whether a dietary change should be made, but only whether changes already made were acceptable. For our diets, peNDF, calculated as the proportion of particles on the top 2 screens multiplied by the total dietary NDF, was not a good predictor of eNDF because just a 3% difference in peNDF between TPH20 and TPH14 resulted in a large difference in milk fat production and overall cow health. In an attempt to account for this difference, we alternately calculated peNDF by multiplying the proportion of particles on the top 2 sieves by the forage NDF concentration rather than by total dietary NDF. Although not different from one another, physically effective forage NDF was 21% greater for TPH20, suggesting that perhaps in diets with large amounts of a non-forage fiber source, this method may better represent true physical effectiveness.

MUN was greatest for TPH20 and least for CON ( $P < 0.05$ ), which agreed with differences in dietary crude protein content. Milk protein yield and percentage were not different among treatment diets, suggesting that the differences in dietary crude protein did not limit milk protein synthesis (Table 3). Despite differences in particle size between TPH20 and CON, few effects on milk components occurred, which suggests that particle size was sufficient to promote a healthy rumen environment.

***Economic Analysis.*** Because WCGF and TPH are relatively low-cost feedstuffs, an economic analysis was conducted to determine if the decreased cost of TPH20 would result in an increased income over feed cost (IOFC, Table 6). Because TPH14 did not prove to be a viable option for ration formulation it was not included in the analysis. Cost per lb of dry matter and feed cost per cow per day were smaller for TPH20 than CON (\$0.081 vs. \$0.086 and \$4.41 vs. \$4.72). In contrast, IOFC was \$0.21 per cow per day greater for CON because of greater milk yield. Table 6 shows the potential income differential of feeding TPH20 versus CON. According to Table 7, feeding TPH20 would not be more profitable than CON until the feed cost margin per cow per day between TPH20 and CON reached at least \$0.35. The potential income differential of feeding TPH20 is greatest when milk prices are low and feed cost margins between the diets are high.

Proximity to a source for WCGF can drastically influence its price because of transportation costs. Therefore, farms closer to the point of origin may realize less expensive ration costs. Even though feeding TPH20 is not always profitable because of decreased milk yield, fluctuating commodity prices, milk price, and proximity to point of origin of WCGF may make it profitable for some producers to feed a ration similar to TPH20.

Although TPH14 apparently did not supply adequate peNDF or forage NDF to the diet, TPH20 offered a feasible option for lactating dairy cows and resulted in component yield and efficiency similar to that of CON. Use of a diet similar to TPH20 may sometimes be economically feasible in a location where WCGF and TPH are readily available. In addition, in an emergency situation in which supplies of other feedstuffs are limited or exhausted, TPH20 could serve as an auxiliary option for dairy producers.

NUTRITION AND FEEDING

**Table 1. Ingredient and nutrient composition of experimental diets**

Item	Treatment diets <sup>1</sup>		
	CON	TPH20	TPH14
Ingredient, % of dry matter (DM)			
Corn silage	17.6	-	-
Alfalfa hay	17.7	-	-
Prairie hay	-	19.2	13.8
WCGF <sup>2</sup>	33.0	46.1	56.0
Cottonseed	7.3	7.5	7.5
Corn grain	16.6	17.5	15.6
Soybean meal (48%)	1.0	2.6	-
SoyBest <sup>3</sup>	4.1	4.2	4.2
Limestone	1.2	1.6	1.7
Magnesium oxide	0.1	0.1	0.1
Sodium bicarbonate	0.8	0.8	0.8
Trace mineral salt	0.5	0.1	0.1
Salt	0.03	-	-
Micronutrient premix <sup>4</sup>	0.13	0.13	0.13
Nutrient, % of DM			
DM, % (as fed)	62.7	60.7	61.5
Crude protein	16.5	18.0	18.6
NE <sub>L</sub> (Mcal/kg)	1.7	1.6	1.7
Neutral detergent fiber (NDF)	34.5	38.3	37.0
Forage NDF	15.3	12.9	9.3
Ether extract	3.6	4.1	3.7
Starch	20.8	13.9	12.1
Ash	10.9	8.9	9.5
Physically effective NDF <sup>5</sup>			
peNDF <sup>8.0</sup>	15.8 ± 1.0 <sup>a</sup>	11.9 ± 1.0 <sup>b</sup>	11.6 ± 2.7 <sup>ab</sup>
peFNDF <sup>8.0</sup>	7.0 ± 0.4 <sup>a</sup>	4.0 ± 0.4 <sup>b</sup>	3.1 ± 1.0 <sup>b</sup>

<sup>a,b</sup> Means within a row having different superscripts differ ( $P < 0.05$ ).

<sup>1</sup> CON = control, TPH20 = tallgrass prairie hay 20%, TPH14 = tallgrass prairie hay 14%.

<sup>2</sup> Wet corn gluten feed (Sweet Bran, Cargill, Inc., Blair, NE).

<sup>3</sup> SoyBest, West Point, NE.

<sup>4</sup> Micronutrient premix consisted of 30.2% Se premix (0.06%), 34.9% 4-Plex (Zinpro Corp., Eden Prairie, MN), 23.3% Vitamin E (44 IU/g), 9.3% Vitamin A (30,000 IU/g), 2.32% Vitamin D (20,000 IU/g).

<sup>5</sup> peNDF<sup>8.0</sup> was calculated as the proportion of particles retained on the top 2 sieves of a Penn State particle separator multiplied by the total dietary NDF concentration.



NUTRITION AND FEEDING

**Table 2. Composition of corn silage, alfalfa hay, wet corn gluten feed (WCGF), and tallgrass prairie hay**

Nutrient <sup>1</sup>	Ingredient			
	Corn silage	Alfalfa hay	WCGF	Tallgrass prairie hay
Dry matter	36.9	89.5	58.5	88.5
Neutral detergent fiber	43.2	43.6	37.5	67.5
Crude protein	8.0	18.3	22.9	6.6
Ether extract	2.9	1.1	2.6	1.7
Ash	5.2	11.4	5.8	7.3

<sup>1</sup> All nutrients except dry matter are expressed as a percentage of diet dry matter.

**Table 3. Effect of treatments on milk component yield and concentration**

Item	Treatment <sup>1</sup>			P-value
	CON	TPH20	TPH14	
Milk fat, lb/day	2.71 ± 0.07 <sup>a</sup>	2.56 ± 0.07 <sup>ab</sup>	2.25 ± 0.13 <sup>b</sup>	0.009
Milk fat, %	3.47 ± 0.13 <sup>a</sup>	3.40 ± 0.13 <sup>a</sup>	2.82 ± 0.19 <sup>b</sup>	0.005
Milk protein, lb/day	2.64 ± 0.06	2.54 ± 0.06	2.71 ± 0.15	0.66
Milk protein, %	3.35 ± 0.05	3.37 ± 0.05	3.37 ± 0.10	0.88
Milk lactose, lb/day	3.81 ± 0.11	3.70 ± 0.11	3.79 ± 0.15	0.24
Milk lactose, %	4.82 ± 0.04	4.85 ± 0.05	4.87 ± 0.11	0.74
Somatic cell count, 1,000 cells/mL	260 ± 76	198 ± 76	190 ± 140	0.62
Milk urea nitrogen, mg/dL	13.9 ± 0.89 <sup>b</sup>	17.0 ± 0.89 <sup>a</sup>	16.5 ± 1.12 <sup>ab</sup>	0.004

<sup>ab</sup> Means within a row having different superscripts differ ( $P < 0.05$ ).

<sup>1</sup> CON = control; TPH20 = tallgrass prairie hay 20%; TPH14 = tallgrass prairie hay 14%.

**Table 4. Particle size separation (% of dry matter)**

% dry matter retained on sieves	Treatment diets <sup>1</sup>			SEM
	CON	TPH20	TPH14	
19.0 mm	18.8	14.7	9.1	6.3
8.0 mm	27.2 <sup>a</sup>	16.0 <sup>b</sup>	21.7 <sup>ab</sup>	4.7
1.18 mm	43.1 <sup>b</sup>	61.6 <sup>a</sup>	55.4 <sup>ab</sup>	7.8
Pan	10.9	7.7	9.2	5.3

<sup>ab</sup> Means within a row having different superscripts differ ( $P < 0.05$ ).

<sup>1</sup> CON = control; TPH20 = tallgrass prairie hay 20%; TPH14 = tallgrass prairie hay 14%.

NUTRITION AND FEEDING

**Table 5. Effect of treatments on dry matter intake (DMI) and performance**

Item	Treatment diets <sup>1</sup>			P-value
	CON	TPH20	TPH14	
No. of observations	53	53	15	
DMI, lb/day	54.8 ± 1.9	54.6 ± 1.9	59.6 ± 2.8	0.24
Milk, lb/day	80.0 ± 2.2 <sup>a</sup>	76.3 ± 2.2 <sup>b</sup>	78.5 ± 2.9 <sup>ab</sup>	0.02
Energy-corrected milk (ECM), lb/day	80.0 ± 1.6 <sup>a</sup>	76.5 ± 1.6 <sup>b</sup>	73.4 ± 2.9 <sup>b</sup>	0.03
ECM/DMI	1.45 ± 0.04	1.40 ± 0.04	1.30 ± 0.09	0.31
Body weight change, lb/21 days	15.9 ± 8.4	29.5 ± 8.4	13.2 ± 11.0	0.71

<sup>ab</sup> Means within a row having different superscripts differ ( $P < 0.05$ ).

**Table 6. Economic analysis of CON and TPH20**

Item	Diet <sup>1</sup>	
	CON	TPH20
\$/lb of dry matter	\$0.086	\$0.081
Feed cost per cow per day	\$4.72	\$4.41
Income per cow per day	\$11.12	\$10.60
IOFC <sup>2</sup>	\$6.40	\$6.19

<sup>1</sup> CON= control; TPH20=tallgrass prairie hay 20%.

<sup>2</sup> Income over feed cost.

**Table 7. Potential income differential of feeding TPH20 across different milk prices and feed costs per cow per day**

Milk price, \$/lb	Potential difference in feed cost per cow per day between CON and TPH20								
	\$0.20	\$0.25	\$0.30	\$0.35	\$0.40	\$0.45	\$0.50	\$0.55	\$0.60
\$0.09	-\$0.14	-\$0.09	-\$0.04	<b>\$0.01</b>	<b>\$0.06</b>	<b>\$0.11</b>	<b>\$0.16</b>	<b>\$0.21</b>	<b>\$0.26</b>
\$0.10	-\$0.17	-\$0.12	-\$0.07	-\$0.02	<b>\$0.03</b>	<b>\$0.08</b>	<b>\$0.13</b>	<b>\$0.18</b>	<b>\$0.23</b>
\$0.11	-\$0.21	-\$0.16	-\$0.11	-\$0.06	-\$0.01	<b>\$0.04</b>	<b>\$0.09</b>	<b>\$0.14</b>	<b>\$0.19</b>
\$0.12	-\$0.24	-\$0.19	-\$0.14	-\$0.09	-\$0.04	<b>\$0.01</b>	<b>\$0.06</b>	<b>\$0.11</b>	<b>\$0.16</b>
\$0.13	-\$0.28	-\$0.23	-\$0.18	-\$0.13	-\$0.08	-\$0.03	<b>\$0.02</b>	<b>\$0.07</b>	<b>\$0.12</b>
\$0.14	-\$0.31	-\$0.26	-\$0.21	-\$0.16	-\$0.11	-\$0.06	-\$0.01	<b>\$0.04</b>	<b>\$0.09</b>
\$0.15	-\$0.34	-\$0.29	-\$0.24	-\$0.19	-\$0.14	-\$0.09	-\$0.04	<b>\$0.01</b>	<b>\$0.06</b>
\$0.16	-\$0.38	-\$0.33	-\$0.28	-\$0.23	-\$0.18	-\$0.13	-\$0.08	-\$0.03	<b>\$0.02</b>
\$0.17	-\$0.41	-\$0.36	-\$0.31	-\$0.26	-\$0.21	-\$0.16	-\$0.11	-\$0.06	-\$0.01
\$0.18	-\$0.45	-\$0.40	-\$0.35	-\$0.30	-\$0.25	-\$0.20	-\$0.15	-\$0.10	-\$0.05
\$0.19	-\$0.48	-\$0.43	-\$0.38	-\$0.33	-\$0.28	-\$0.23	-\$0.18	-\$0.13	-\$0.08

# Lysine Degradation by Ruminal *Fusobacterium necrophorum*

E. A. Elwakeel<sup>1</sup>, R. G. Amachawadi<sup>2</sup>, A. M. Nour<sup>1</sup>, M. E. Nassar<sup>1</sup>, T. G. Nagaraja<sup>2</sup>, and E. C. Titgemeyer

## Summary

Three experiments were conducted to characterize lysine fermentation by *Fusobacterium necrophorum*, a ruminal bacterium that is known to degrade amino acids. In Experiment 1, 7 strains of *Fusobacterium necrophorum* were inoculated into media containing lysine (50 mM), lactate (50 mM), or lysine plus lactate (50 mM each) as the major energy substrate to evaluate growth and ammonia production. All strains grew with lysine, lactate, or lactate plus lysine as the primary substrate. When grown with lysine, all strains produced ammonia as an end product, even if lactate was also present. Smaller concentrations of ammonia for medium containing lactate plus lysine when compared with lysine alone indicate that the *Fusobacterium* strains used lactate as a growth substrate that stimulated utilization of ammonia. In Experiment 2, the 2 strains tested were able to degrade extensively both lysine and glutamic acid. Some evidence was detected for partial utilization for growth of histidine, methionine, and tryptophan by strain A21. In Experiment 3, the minimum inhibitory concentration (MIC) of the antibiotic tylosin was 25 µg/mL when *Fusobacterium necrophorum* strains A21 and B35 were grown in either lysine or lactate-enriched medium. The MIC of monensin was 6.25 and 3.9 µg/mL for strains A21 and B35, respectively, when grown in lysine-enriched medium, but > 50 and 10.9 µg/mL when the strains were grown in lactate-enriched medium. These findings may lead to ways that ruminal lysine degradation may be controlled.

**Key words:** bacterial digestion, lactate, lysine degradation

## Introduction

High milk-producing dairy cows require a well balanced supply of amino acids. Lysine is often a limiting amino acid for dairy cows, especially when they are fed diets containing large amounts of corn proteins. Degradation of amino acids by ruminal microorganisms, however, makes it impossible to increase lysine supply to the cow by simply adding more lysine to the diet. Therefore, much research has been conducted to find ways to protect lysine from ruminal degradation.

Besides protecting lysine from ruminal degradation, altering the ability of ruminal microbes to degrade lysine might also be possible. A better understanding of lysine degradation by ruminal microorganisms could lead to opportunities to control lysine degradation in the rumen. In general, amino acids in the rumen are degraded by bacteria that are classified as hyper-ammonia producing bacteria, which exist in small numbers in the rumen but nonetheless produce large amounts of ammonia by degradation of amino acids. *Fusobacterium necrophorum* has been identified as a hyper-ammonia producing bacterium. It has been isolated from rumen fluid enriched with lysine as a growth substrate, suggesting that *Fusobacterium necrophorum* may be one of the major bacteria that contributes to lysine degradation in the rumen.

<sup>1</sup> Department of Animal Production, Alexandria University, Alexandria, Egypt 21545

<sup>2</sup> Department of Diagnostic Medicine/Pathobiology

## NUTRITION AND FEEDING

Our objectives were to: 1) identify the ability of ruminal *Fusobacterium necrophorum* to degrade lysine with or without the presence of lactate; 2) study the ability of *Fusobacterium necrophorum* to degrade a range of amino acids; and 3) evaluate the minimum inhibitory concentration (MIC) of tylosin and monensin against *Fusobacterium necrophorum* strains when their growth media contained lysine or lactate as the major energy source.

### Experimental Procedures

**General methods.** Basal medium for growing *Fusobacterium* contained 292 mg  $K_2HPO_4$ , 292  $KH_2PO_4$ , 480 mg  $(NH_4)_2SO_4$ , 480 mg NaCl, 100 mg  $MgSO_4 \times 7 H_2O$ , 64 mg  $CaCl_2 \times 2 H_2O$ , 1 g trypticase, and 0.5 g yeast extract dissolved in deionized water to a final volume of 1 L. *Fusobacterium necrophorum* strains were grown anaerobically in blood agar plates. A single colony of each strain was inoculated into anaerobic brain heart infusion broth supplemented with cysteine hydrochloride and incubated. Then, samples of each culture tube were inoculated into brain heart infusion broth and incubated before being diluted and used for inoculation.

**Experiment 1.** Media were enriched with lysine (50 mM), lactate (50 mM), or lactate plus lysine (50 mM each) by dissolving in the basal medium and adjusting to pH 7.0. Seven strains of *Fusobacterium necrophorum* (A21, A27, A29, B33, B34, B35, and B36) were inoculated into the enriched media and incubated for 48 hours at 37°C. Optical density was measured every 12 hours to measure growth, and samples for ammonia analysis were collected at the end of the experiments by acidifying culture media with *m*-phosphoric acid.

**Experiment 2.** Basal media preparations were enriched with 50 mM of the amino acids L-tryptophan, L-alanine, L-glutamic acid, L-methionine, L-histidine, or L-lysine. Media were inoculated with ruminal *Fusobacterium necrophorum* strains A21 or B35.

**Experiment 3.** Ruminal *Fusobacterium necrophorum* strains A21 and B35 were used for MIC determination. Stock solutions of tylosin and monensin contained 1 mg/mL of each antibiotic. The MIC was determined by using 96-well plates with concentrations of each antibiotic ranging from 50 to 0.097  $\mu$ g/mL. The MIC was determined as the least concentration of antibiotic at which no bacterial growth was observed.

### Results and Discussion

**Experiment 1.** All strains of ruminal *Fusobacterium necrophorum* had the ability to grow in media enriched with lysine, lactate, or lactate plus lysine. *Fusobacterium necrophorum* strains grown in medium containing lysine produced more ( $P < 0.01$ ) ammonia than those receiving only lactate, indicating the degradation of the lysine (Table 1). The smaller concentration of ammonia for lactate plus lysine than for lysine alone is likely reflective of greater uptake of ammonia as a consequence of greater bacterial growth. The previous conclusion is supported by estimates of growth based on optical density (data not shown). These results demonstrate that ruminal *Fusobacterium necrophorum* has the ability to use lysine as the sole energy source, which agrees with the general characteristics of other *Fusobacterium* species reported by others.

**Experiment 2.** Results of ammonia concentrations (Table 2) and optical density values (data not shown) demonstrated that ruminal *Fusobacterium necrophorum* strains A21 and B35 degraded glutamic acid and lysine nearly completely by 48 hours of incubation. Some evidence supported partial utilization for growth of some other amino acids such as histidine, methionine, and tryptophan for strain A21. To date, however, little research exists supporting the

## NUTRITION AND FEEDING

ability of ruminal strains of *Fusobacterium necrophorum* to degrade amino acids and use them as the sole energy source.

**Experiment 3.** The MIC for tylosin was 25 µg/mL for both *Fusobacterium necrophorum* strains A21 and B35 whether they were grown in lactate or lysine-enriched media (Table 3). Thus, the sensitivity of *Fusobacterium necrophorum* to tylosin seems to be independent of growth substrate.

When they were grown in the lactate-enriched medium, the MIC for monensin was more than 50 µg/mL for strain A21 and 10.9 µg/mL for strain B35. In contrast, when they were grown in the lysine-enriched medium, the MIC for monensin was 6.25 µg/mL for strain A21 and 3.9 µg/mL for strain B35, demonstrating that both strains were much more sensitive to the antibiotic effects of monensin when growing on lysine than when growing on lactate (Table 3). Ruminal *Fusobacterium necrophorum* is a gram negative bacterium, but some research showed that its growth could be inhibited by monensin at concentrations of 5 µM. Previous research found that monensin could reduce the transport (uptake) of lysine by bacteria, which could explain our results.

In general, our results indicate that tylosin and monensin may reduce *Fusobacterium necrophorum* in the rumen, and hence might control lysine degradation in the rumen and make it more available for the animal.

NUTRITION AND FEEDING

**Table 1. Ammonia concentration (mM) after 48 hours of incubation of various *Fusobacterium necrophorum* strains in media enriched with lactate, lysine, or lactate plus lysine**

Strain	Medium contents <sup>1</sup>		
	Lactate <sup>c</sup>	Lysine <sup>a</sup>	Lactate + lysine <sup>b</sup>
A21	7.5	97.0	68.7
A27	11.8	94.8	54.1
A29	12.2	96.4	52.7
B33	11.9	72.0	40.7
B34	11.8	71.7	37.6
B35	8.5	98.0	47.1
B36	13.2	80.0	45.0

<sup>a,b,c</sup> Media enrichments not bearing a common letter differ ( $P < 0.01$ ). Media enrichments and strain affected ( $P \leq 0.05$ ) ammonia concentration, but their interaction was not significant.

<sup>1</sup> Largest SEM among treatments = 9.6.

**Table 2. Ammonia concentration (mM) after 48 hours of incubation of *Fusobacterium necrophorum* strains in media enriched with various amino acids**

Strain	Control <sup>c,d</sup>	Amino acid <sup>1</sup>					
		Lys <sup>a</sup>	Ala <sup>d,e</sup>	Trp <sup>e,f</sup>	Met <sup>f</sup>	His <sup>c</sup>	Glu <sup>b</sup>
A21	12.2	91.5	10.9	6.6	6.4	17.0	51.0
B35	10.7	81.4	8.3	6.0	4.3	11.4	49.7

<sup>a,b,c,d,e,f</sup> Amino acids not bearing a common letter differ ( $P < 0.05$ ). Amino acid and strain affected ( $P < 0.01$ ) ammonia concentration, but their interaction was not significant.

<sup>1</sup> Lys = lysine; Ala = alanine; Trp = tryptophan; Met = methionine; His = histidine; Glu = glutamic acid. Largest SEM among treatments = 2.5.

**Table 3. Minimal inhibitory concentration of tylosin and monensin on *Fusobacterium necrophorum* strains in lysine- or lactate-enriched media**

Strain	Minimal inhibitory concentration ( $\mu\text{g/mL}$ )		
	Media enrichment	Tylosin	Monensin
A21	Lysine	25	6.25
A21	Lactate	25	>50
B35	Lysine	25	3.9
B35	Lactate	25	10.9

# Bioavailability of Lysine from Hydroxymethyl Lysine

*E. A. Elwakeel<sup>1</sup>, E. C. Titgemeyer, B. R. Faris, D. W. Brake, A. M. Nour<sup>1</sup>, and M. E. Nassar<sup>1</sup>*

## Summary

Twelve mature sheep were used as a ruminant model to estimate the bioavailability of lysine in hydroxymethyl lysine (HML) compared with a commercial product of rumen-protected lysine (RPL; LysiPEARL, Kemin Industries, Inc.) with known availability. The sheep were fed a diet with a forage to concentrate ratio similar to that of dairy diets. Following a control period in which plasma lysine was measured when sheep received no supplemental lysine, the sheep were provided 2 of 4 treatments during periods 2 and 3; treatments included RPL to provide 3 or 6 g/day of available lysine (actual amounts of product provided were based on the manufacturer's data related to ruminal escape and intestinal availability) and 3 or 6 g/day of lysine provided as HML. Blood samples were collected at the end of each feeding period at 3 hours after feeding. Both HML and RPL significantly increased plasma lysine concentrations. By comparison with plasma lysine concentrations when known amounts of bioavailable lysine were provided as RPL, the bioavailability of lysine in HML was estimated to be 94%. Results indicate that HML may be an effective means of supplementing lysine to dairy cattle.

**Key words:** lysine bioavailability, rumen-protected lysine, sheep

## Introduction

Ruminant microbial protein provides a well balanced source of amino acids for dairy cows, but the amount of amino acids is often not sufficient for high-producing cows. Lysine is considered a limiting amino acid for dairy cows, especially when they are fed corn-based diets. Amino acids can be degraded by rumen microorganisms, and this has led ruminant nutritionists to investigate methods to protect lysine from ruminal degradation such that lysine can be made available in the small intestine for absorption. Protected forms of lysine, however, not only should be protected from ruminal degradation, but also should be available for intestinal absorption. Little research exists on hydroxymethyl lysine (HML) as a source of lysine for dairy cattle, although one study reported a lack of response to HML and suggested that this might be the result of the low pH of the diet (corn silage) leading to degradation of the HML. The goal of this research was to study the intestinal availability of the lysine from HML using sheep as a model by monitoring plasma lysine concentrations compared with observations of a commercial product of known intestinal availability.

## Experimental Procedures

Twelve mature black-faced ewes (77.4 kg) were housed in a large pen (6 x 12 meters) at the Kansas State University Sheep and Goat Center. They were limit-fed (1.6 kg/day, dry matter basis) individually twice daily (7 a.m. and 7 p.m.) for 3 consecutive periods (7 days each). The diet comprised 45.5% alfalfa hay, 44.7% rolled corn, 4.1% soybean meal, 5.1% molasses and 0.57% salt, and it contained 15.4% crude protein and 23.4% neutral detergent fiber (NDF; dry matter basis). During meals, sheep were placed in individual feeding pens (18 inches wide) for 30 minutes.

<sup>1</sup> Department of Animal Production, Alexandria University, Alexandria, Egypt 21545

## NUTRITION AND FEEDING

The first period was a control period with no lysine supplementation, and blood samples were collected at the end of this period to serve as baseline measurements. The second and third periods were treatment periods. Diets were mixed with 3 or 6 g/day of available lysine from a commercial product of rumen-protected lysine (**RPL**; LysiPEARL, Kemin Industries, Inc.; 21% of product weight was intestinally available lysine) or with HML in amounts that contained 3 or 6 g/day of total lysine. Hydroxymethyl lysine was manufactured in our lab as described in U.S. Patent No. 4,073,945 by the reaction of lysine-HCl with formaldehyde (1.32 moles formaldehyde per mole lysine) in an aqueous solution containing calcium hydroxide (1 mole calcium hydroxide per mole of lysine). Formaldehyde was added with the temperature of the solution near 15°C, then the mixture was stirred for 3 hours, cooled to 5°C, collected on filter paper, and rinsed with cold water. The product was dried in a 55°C oven for 24 hours and then in a vacuum oven at 55°C for an additional 24 hours.

On the final day of each period, blood samples (10 mL) were collected by jugular venipuncture at 3 hours after the morning feeding. Blood samples were placed on ice directly after collection, transferred to the lab, and then centrifuged at  $1,000 \times g$  for 15 minutes. Plasma was transferred to microcentrifuge tubes and frozen at  $-20^{\circ}\text{C}$  pending later analysis of amino acids by HPLC.

### Results and Discussion

A linear increase of plasma lysine was detected after either HML ( $P < 0.01$ ) or RPL ( $P < 0.01$ ) supplementation, but no statistical difference ( $P = 0.78$ ) was detected between the slopes of the regression lines of lysine concentration plotted against HML and RPL supplementation levels (Figure 1). The relative bioavailability of lysine from HML compared with RPL was 94% (not statistically different from 100%), calculated by dividing the slope for HML by that for RPL. Because the amounts of RPL were based on amounts of available lysine, the 94% availability for lysine in HML can be considered a true availability value for HML. Similar conclusions were drawn when plasma lysine as a percentage of total plasma amino acids was used as the response criteria, which strengthens our conclusions.

Hydroxymethyl lysine is a chemical derivative of lysine that has the amino groups chemically attached to a reactive hydroxymethyl group such that the lysine is unavailable to ruminal microbes. The acidic pH of the abomasum, however, releases lysine from the complex and hence the lysine becomes available for intestinal absorption. Because the product is acid labile, acidic diet ingredients such as silages should be considered when mixing with the product because they might release the lysine from HML before feeding.

In conclusion, our results show that HML can be used as an effective source of lysine for ruminant animals and may be an effective product for dairy cattle diets.



## NUTRITION AND FEEDING

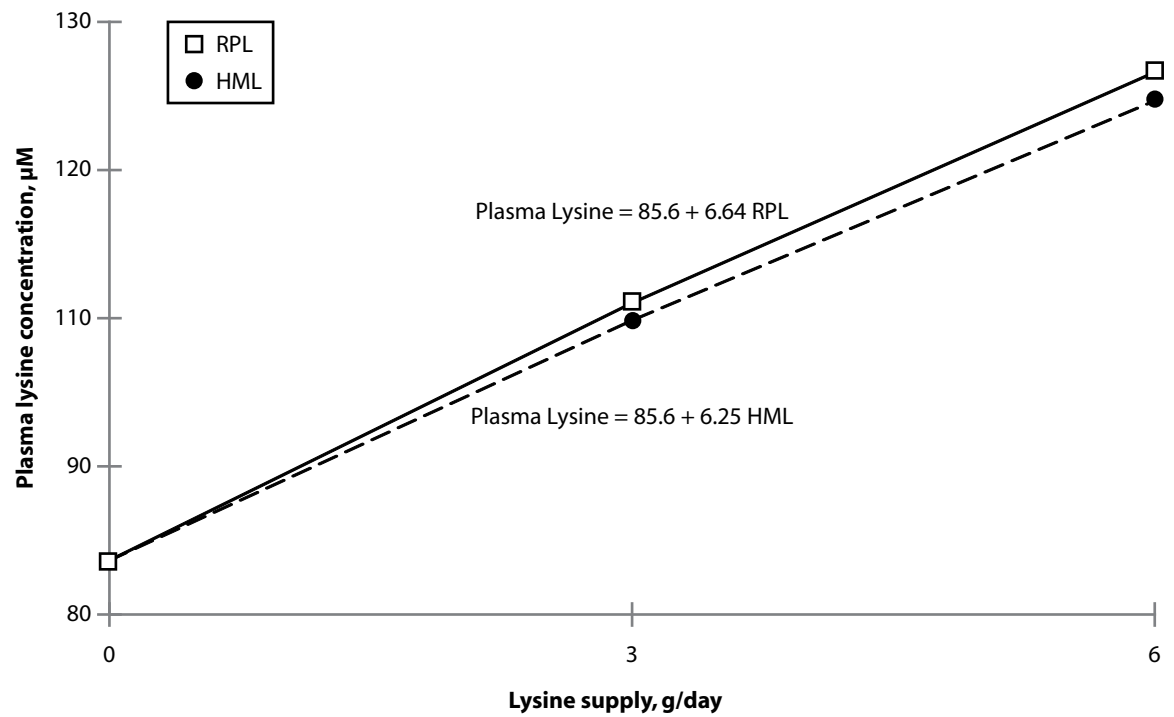

**Figure 1: Effect of hydroxymethyl lysine (HML) and rumen protected lysine (RPL) on plasma lysine concentrations of sheep.**

The RPL was provided as amounts of available lysine, whereas HML was provided in amounts of total lysine. Both sources increased ( $P < 0.01$ ) plasma lysine concentrations. Slopes were similar between lysine products ( $P = 0.78$ ).

# Effects of Continuous Infusion of Tumor Necrosis Factor-Alpha into Adipose Tissue on Glucose and Fatty Acid Metabolism in Lactating Dairy Cattle

*C.A. Martel, L. K. Mamedova, J.E. Minton, M.L. Jones<sup>1</sup>, J. A. Carroll<sup>2</sup>, and B.J. Bradford*

## Summary

Recent work has suggested that inflammation, possibly originating in adipose tissue, can alter liver metabolism in lactating cows. In this experiment, Holstein cows were used to evaluate effects of tumor necrosis factor-alpha (**TNF $\alpha$** ) administration on glucose and fatty acid metabolism. Eighteen late-lactation cows were assigned randomly to control or **TNF $\alpha$**  treatments. Treatments (4 mL saline or 14  $\mu$ g/kg **TNF $\alpha$**  in 4 mL saline) were infused continuously over 7 days via 2 osmotic pumps in the tailhead adipose depot. Plasma, milk samples, milk yield, and dry matter intake data were collected daily, and liver and adipose tissue samples were collected for analysis of gene expression at the end of the treatment period. Contrary to expectations, **TNF $\alpha$**  did not alter markers of inflammation in plasma, dry matter intake, or rectal temperature. Treatments also failed to alter plasma non-esterified fatty acids (**NEFA**) concentration, liver triglyceride content, or adipose mRNA abundance for hormone-sensitive lipase or perilipin. Plasma glucose turnover rate, as measured by disappearance of U-<sup>13</sup>C-glucose bolus, was not altered by treatment, nor was liver mRNA abundance for phosphoenolpyruvate carboxylase or pyruvate carboxylase. In contrast, **TNF $\alpha$**  tended ( $P = 0.09$ ) to decrease adipose **TNF $\alpha$**  mRNA abundance and increased ( $P = 0.05$ ) liver IL-10 mRNA abundance compared with controls.

**Key words:** fatty acids, glucose, liver, tumor necrosis factor-alpha

## Introduction

Nearly 50% of early lactation dairy cattle are estimated to suffer from subclinical or clinical fatty liver disease. Fatty liver disease results from an accumulation of fat within the liver; normally the liver is not a storage site for fat. Many metabolic disorders are associated with fatty liver disease (ketosis, displaced abomasum, mastitis, and postpartum anestrus), and often multiple disorders occur simultaneously, often leading to culling. Cows diagnosed with fatty liver have decreased liver glucose production and fatty acid oxidation, but exact mechanisms responsible for these adverse changes are unclear.

During fatty liver disease, animals can suffer from inflammation similar to that seen in cases of septic shock. To study the role of inflammation in fatty liver disease, we have investigated the ability of tumor necrosis factor-alpha (**TNF $\alpha$** ) to directly induce changes in liver function and composition. A key cytokine, **TNF $\alpha$** , is activated during infection and it is known to induce inflammation in the liver.

Studies have shown that **TNF $\alpha$**  promotes mobilization of energy stores by impaired insulin sensitivity, decreased feed intake, and direct stimulation of lipolysis, all conditions associated with

<sup>1</sup> Dept. of Clinical Sciences, Kansas State University.

<sup>2</sup> Livestock Issues Research Unit, ARS, USDA, Lubbock, TX.

fatty liver. In our preliminary work, cows injected subcutaneously once daily with TNF $\alpha$  had a significant increase in liver fat content, suggesting that this inflammatory cytokine can promote fatty liver. In addition, this treatment seemed to decrease the ability of the liver to produce glucose.

In this experiment, our objective was to assess the effects of continuous (rather than once daily) TNF $\alpha$  administration on inflammatory markers, lipolysis, liver triglycerides, glucose production, liver and adipose mRNA abundance in lactating cows.

## Experimental Procedures

Late-lactation Holstein cows were used to evaluate effects of TNF $\alpha$  administration on glucose and fatty acid (FA) metabolism. Eighteen cows were blocked by feed intake and milk yield and assigned randomly within block to a control or TNF $\alpha$  treatment. Saline (4 mL) or TNF $\alpha$  (14  $\mu$ g/kg in 4 mL saline) were infused continuously over 7 days via 2 osmotic pumps in the adipose layer in the tail head region. Plasma, milk samples, milk yield, and dry matter intake were collected daily. Plasma was analyzed for beta-hydroxybutyrate (BHBA), non-esterified fatty acids (NEFA), and glucose. On treatment day 6, all cows were given a glucose bolus containing U-<sup>13</sup>C-glucose, and blood samples were then collected at 10-minute intervals for 2 hours to determine glucose turnover rate. On day 7, pumps were removed and liver and contralateral tailhead adipose samples were collected for analysis of liver triglyceride (fat) and mRNA for key transcripts.

All cows were housed in the Kansas State University Dairy Teaching and Research Center tie-stall barn during the duration of the study. Feed was offered twice daily (7:00 a.m. and 6:00 p.m.), and cows were milked thrice daily. Results were modeled with fixed effect of treatment and random effect of block.

## Results and Discussion

We expected that TNF $\alpha$  administration would induce fatty liver disease, decrease plasma glucose turnover rate, and increase plasma NEFA and liver triglyceride concentration. In contrast, administration of TNF $\alpha$  during the 7-day period via osmotic pumps did not alter adipose or liver TNF $\alpha$  mRNA abundance; plasma TNF $\alpha$ , IL-4, IL-6 (interleukins; a group of cytokines secreted by white blood cells during inflammation), or interferon- $\gamma$  concentrations; dry matter intake; or rectal temperature. Milk fat and lactose concentrations decreased ( $P < 0.05$ ), with TNF $\alpha$ , but milk yield was unchanged and treatments did not alter the proportion of short vs. long-chain FA in milk on day 7. Treatments did not alter plasma NEFA concentration, liver triglyceride content, or adipose mRNA abundance for hormone-sensitive lipase or perilipin. Plasma glucose turnover rate, as measured by disappearance of U-<sup>13</sup>C-glucose bolus, was not altered by treatment, nor was liver mRNA abundance for 2 enzymes critical for glucose production (Table 1).

The lack of treatment effects on inflammatory markers clearly indicates that continuous infusion of TNF $\alpha$  did not induce the same responses as when it was delivered in a single injection once daily. In fact, in this experiment TNF $\alpha$  tended ( $P = 0.09$ ) to decrease adipose TNF $\alpha$  mRNA abundance and increase ( $P = 0.05$ ) liver interleukin-10 (an anti-inflammatory cytokine) mRNA abundance compared with controls. Both of these responses indicate that the TNF $\alpha$ -treated cows had a less inflammatory state than the control, the opposite of the response expected based on previous results. Such a response possibly was caused by an adaptive anti-

## NUTRITION AND FEEDING

inflammatory response to the TNF $\alpha$  infusion. In other words, it seems as if the slow, constant administration of the cytokine allowed the cows to counteract the inflammatory challenge. These findings indicate that brief, rapid increases in inflammatory cytokines may be more likely to induce liver inflammation than chronic, low-level increases, at least during the course of 7 days.

When the immune system is stimulated by rapid increases in cytokine concentrations, it sets off a cascade of events that lead to activation of inflammatory pathways, which can trigger metabolic changes. In contrast, these results suggest that slow, low-level increases in cytokine secretion are less likely to induce systemic inflammation and metabolic dysfunction.

Administration of TNF $\alpha$  through osmotic pumps did not alter feed intake or milk production. Adipose and liver tissue triglyceride metabolism and glucose metabolism remained unchanged by TNF $\alpha$  treatment. Tendencies for effects on liver IL-10 mRNA and adipose TNF $\alpha$  mRNA suggest that TNF $\alpha$  administration may have stimulated an adaptive anti-inflammatory response to suppress systemic inflammation during the 7-day infusion. The lack of metabolic responses, in contrast with previous responses to daily subcutaneous TNF $\alpha$  injections, may be explained by the lack of systemic inflammation in this study. Future work will be designed to investigate the role of TNF $\alpha$  in feed restriction-induced fatty liver.

**Table 1. Effects of TNF $\alpha$  administration on liver triglyceride (TG) and plasma metabolites on day 7 of treatment**

Metabolic variable	Treatment <sup>1</sup>		SEM	P value
	Control	TNF		
Liver TG, mg/g protein	21.1	10.1	5.2	0.26
Plasma NEFA, $\mu$ Eq/L	127	134	20	0.81
Plasma BHBA, mg/dL	156	267	27	0.84
Glucose turnover rate, g/min	2.76	2.52	0.16	0.24

<sup>1</sup> Control: continuous infusion of 4 mL of sterile saline over 7 days; TNF: continuous infusion of 14  $\mu$ g/kg TNF $\alpha$  over 7 days.

# Ovarian Characteristics, Serum Hormone Concentrations, and Fertility in Lactating Dairy Cows in Response to Equine Chorionic Gonadotropin

*S. L. Pulley, L. D. Wallace, H. I. Mellieon, and J. S. Stevenson*

## Summary

The objective of this study was to evaluate the effects of equine chorionic gonadotropin (eCG) on various characteristics associated with an effective timed artificial insemination (AI) protocol in lactating dairy cows. Cows ( $n = 121$ ) in a single herd were treated with 2 injections of prostaglandin  $F_{2\alpha}$  (PGF $_{2\alpha}$ ) 14 days apart (Presynch), with the second injection administered 11 days before the onset of a timed AI protocol. Cows received either saline or 400 IU eCG concurrent with the PGF $_{2\alpha}$  injection of the Ovsynch protocol (injection of gonadotropin-releasing hormone or GnRH, 7 days before and 48 to 56 hours after PGF $_{2\alpha}$  with insemination occurring 12 to 16 hours after the second GnRH injection). Blood samples were collected during the study to monitor serum changes in progesterone and estradiol in order to determine if eCG would facilitate increased estrual activity, improved ovulatory response, and enhanced postovulatory luteal function. Administration of eCG tended to increase the number of corpora lutea (CL) and on days 9 and 16 after PGF $_{2\alpha}$ , corresponding to days 6 and 13 postovulation, but the volume of the luteal tissue was less than that in the control. Timed AI pregnancy rates did not differ between eCG (36.9%) and control cows (41.8%). We concluded that use of eCG provided no profertility advantages to dairy cattle when programmed for a timed insemination at first service.

**Key words:** corpus luteum, equine chorionic gonadotropin, follicle, progesterone, timed artificial insemination (AI)

## Introduction

Cows inseminated at first service after detected estrus have better conception rates than those inseminated by appointment in an ovulation-synchronization program (40.7 vs. 33.5%; Stevenson and Phatak, Dairy Research 2009, Report of Progress 1021, pp. 56-62), but not as good as cows in estrus at the timed artificial insemination (AI; 51.8%). Earlier work demonstrated that when estradiol cypionate was administered as part of a timed AI program, pregnancy outcomes tended to be improved. Because dairy cows have greater rates of metabolism of steroids and produce large quantities of milk, their circulating concentrations of progesterone and estradiol are less in comparison with nonlactating heifers despite having larger corpora lutea (CL) and larger follicles, respectively. It seems that some lactating dairy cows lack sufficient serum concentrations of estradiol to support and facilitate strong estrual activity.

Equine chorionic gonadotropin (eCG) is a member of the glycoprotein family, which includes follicle stimulating hormone (FSH) and luteinizing hormone (LH). It is secreted by the trophoblast cells of the chorionic girdle in the pregnant mare beginning approximately at 37 days of gestation. In the mare, eCG elicits a similar response to that of LH. In contrast, in other species, eCG acts like FSH. The FSH properties of eCG have led to its use as an exogenous hormone preparation for stimulation of follicular growth and superovulation in farm animals.

## REPRODUCTION

Administration of eCG has been shown to increase the diameter of the preovulatory follicle, thus suggesting the potential for increasing circulating estradiol concentrations and more estrual activity. Despite a similar-sized preovulatory follicles and CL, administration of eCG increased circulating progesterone concentrations in cross-breed lactating beef cows and Holstein dairy cows. Equine CG may serve as an exogenous treatment to increase plasma concentrations of progesterone and estradiol, while stimulating estrual activity.

The objective of this study was to evaluate the effects of eCG administration on preovulatory follicle diameter, circulating estradiol and progesterone concentrations, CL diameter, estrous activity, and pregnancy rates in lactating dairy cows whose ovulation is synchronized before first service.

### Experimental Procedures

Lactating Holstein cows (72 multiparous and 49 primiparous) from the Kansas State University Dairy Teaching and Research Center were enrolled in the study. Cows were housed in covered free stalls and fed twice daily a total mixed ration (TMR) calculated to meet or exceed the nutrient requirements for a lactating Holstein cow producing 110 lb of milk with 3.5% milk fat. The diet consisted of corn silage, sweet bran, cracked corn, alfalfa hay, whole cottonseed, soybean meal, vitamins, and minerals. Seventeen breeding clusters were formed every 14 days as cows and heifers calved. Cows were blocked by lactation number and days in milk, and assigned randomly to 2 treatments (Figure 1). Body condition scores (BCS; 1=thin and 5=fat) were assigned on day -7 for each cow. Inseminations occurred between April and November 2009. Cows were assigned to treatments at random stages of the estrous cycle and administered 2 PGF<sub>2 $\alpha$</sub>  injections (Presynch; 2 mL Estrumate, Schering-Plough Animal Health, Union, NJ; 5 mL Lutalyse, Pharmacia Animal Health, New York, NY) injections 14 days apart followed by a timed AI protocol (Ovsynch). The Ovsynch protocol consisted of 2 injections of 100  $\mu$ g gonadotropin-releasing hormone (GnRH; Fertagyl, Intervet, Millsboro, DE) 9 days apart with a 25 mg PGF<sub>2 $\alpha$</sub>  injection administered 48 hours before a second injection of GnRH. Cows received either 400 IU eCG (Novormon 5000, Vetrepharm Canada Inc., London, ON; Pregnecol 6000, Bioniche, Belleville, ON) concurrent with PGF<sub>2 $\alpha$</sub>  or no further treatment (control). Cows were inseminated 72 hours after PGF<sub>2 $\alpha$</sub>  (16 hours after the second GnRH injection). Pregnancy was initially diagnosed at 33 days post-AI and reconfirmed at 61 days by transrectal ultrasonography. Pregnancy loss was calculated between the 2 pregnancy diagnoses.

All cows were fitted with HeatWatch transmitters (Cow Chips LLC, Denver, CO) on day -7 to quantify standing estrus and characteristics of estrus during the 96-hour period encompassing the breeding week (post-PGF<sub>2 $\alpha$</sub>  injection). Transmitter function was tested on day -7 and 0. Cows were moved into a dirt lot twice daily for 30 minutes during the breeding week for visual detection of estrus and to aid in expression of estrous activity. Cows were considered to be in standing estrus when 2 mounts of 2 seconds or longer in duration within a 24 hour period were recorded by the HeatWatch system.

Ovaries of all cows were examined via transrectal ultrasonography using an Aloka 500V ultrasound scanner equipped with 5.0 MHz linear probe to determine the structures present in each ovary on days -7, 0, 2, 4, 9, and 16. A structural map of each ovary was drawn with the position and diameter of follicles  $\geq$  5 mm in diameter and each CL, which allowed for evaluation of visual luteolysis and ovulatory response to both GnRH injections (days -7 and 4), preovulatory follicle diameter, and CL diameters on days 9 and 16. Follicle diameter was determined by av-

eraging the measurements of follicular width and length taken at the widest point and perpendicular to the first measurement using the internal calipers of the Aloka 500V. Ovulation on day 4 was defined as disappearance of one or more follicles  $\geq 8$  mm in diameter from an ovary, which a follicle had been recorded on the previous scan of that ovary, followed by the formation of a CL (Figure 1).

Blood was sampled from all cows by puncture of the coccygeal vein or artery into evacuated tubes (BD Vacutainer, Franklin Lakes, NJ). Blood samples were collected days  $-7, 0, 2, 4, 9,$  and  $16$  for progesterone assay. At pregnancy diagnosis, on days  $33$  and  $61$ , blood samples also were collected from pregnant cows for later progesterone assay. Additional blood samples were collected every 24 hours from days  $0$  to  $3$  for estradiol assay. Samples were immediately cooled and stored at  $5^{\circ}\text{C}$  for 16 hours. Blood tubes were centrifuged at  $1,000 \times g$  for 15 minutes in a refrigerated centrifuge at  $5^{\circ}\text{C}$  for serum separation and harvest. Serum samples were frozen and stored at  $-20^{\circ}\text{C}$  until assayed for progesterone and estradiol by radioimmunoassay.

## Results and Discussion

Results are summarized by treatment in Table 1. Progesterone concentrations did not differ between treatments at  $\text{PGF}_{2\alpha}$  injection on day 0 of the protocol or 24 hours before timed AI. Regression of the CL after  $\text{PGF}_{2\alpha}$  injection on day 0 did not differ between treatments whether determined by visual observation of the CL (monitored by transrectal ultrasonography) or by changes in serum progesterone concentration. Likewise, estradiol concentrations did not differ between treatments at  $\text{PGF}_{2\alpha}$  injection or 24 hours before timed AI. Incidences of single or multiple ovulations in response to the first or second GnRH injection did not differ between treatments. Volume of the CL on day 9 was not different between treatments. In contrast, the CL volume on day 16 was greater ( $P = 0.04$ ) for cows receiving eCG treatment, but concentrations of progesterone did not differ between treatments. Cows treated with eCG tended ( $P < 0.10$ ) to have an increased number of CL on day 9 and 16 (Table 1).

A treatment by time interaction was observed for estradiol concentrations during the collection period. Concentrations of estradiol gradually increased from (eCG =  $2.45$  vs. Control =  $2.68$  pg/mL) day 0 to day 2 ( $4.24$  vs.  $4.0$  pg/mL), at which time concentrations progressively decreased ( $2.0$  vs.  $2.0$  pg/mL). Estradiol concentrations did not differ between treatments from days 0 to 3 (Figure 2).

Concentrations of progesterone decreased rapidly from days 0 to 2 after the injection of  $\text{PGF}_{2\alpha}$  administered on day 0. Increased progesterone concentrations from days 2 to 4 are the result of GnRH-induced ovulation of a preovulatory follicle and subsequent CL formation. Progesterone concentrations, however, did not differ between treatments from days 0 to 4 after eCG treatment.

Pregnancy rates did not differ between treatments at either 33 or 61 days (Table 2). Pregnancy loss between the first and second pregnancy diagnoses was numerically lesser for the eCG treated cows; however, no significant difference was detected between treatments.

Administration of eCG failed to change any characteristic studied except for increased luteal volume by day 16 postovulation. Increased luteal volume has been previously observed in beef cattle treated at similar times relative to AI. Despite increased luteal volume by day 16, we were unable to detect an increase in progesterone concentration as reported in beef cattle.

REPRODUCTION

**Table 1. Effect of equine gonadotropin (eCG) on steroid concentrations, ovarian structures, and ovulation characteristics in lactating dairy cows**

Item	Treatment <sup>1</sup>		P-value
	eCG	Control	
Progesterone, ng/mL			
At PGF <sub>2α</sub>	5.75 ± 0.3	5.69 ± 0.3	0.90
24 hours before AI	0.82 ± 0.3	0.43 ± 0.3	0.41
2 days post-AI	0.63 ± 0.3	0.79 ± 0.3	0.73
CL regression <sup>2</sup>			
Visual, %	97.0	94.0	0.51
Based on changes in progesterone, %	80.0	82.0	0.89
Estradiol, pg/mL			
At PGF <sub>2α</sub>	2.45 ± 0.2	2.84 ± 0.3	0.29
24 hours before AI	4.24 ± 0.2	4.00 ± 0.3	0.52
First GnRH			
Ovulation <sup>3</sup> , %	63.6 ± 0.5	69.1 ± 0.5	0.52
Double ovulation <sup>4</sup> , %	21.4 ± 0.4	19.0 ± 0.4	0.86
Second GnRH			
Ovulation <sup>5</sup> , %	96.9	100.0	0.15
Double ovulation <sup>6</sup> , %	20.3	18.2	0.73
Ovulatory follicle diameter, mm			
Primary follicle	13.9 ± 0.3	15.0 ± 0.48	0.08
Secondary follicle	11.0 ± 0.4	13.9 ± 0.5	0.004
Corpora lutea (CL) volume, cm <sup>3</sup>			
Day 9	6.57 ± 0.5	6.97 ± 0.51	0.40
Day 16	9.1 ± 0.5 <sup>a</sup>	7.7 ± 0.5 <sup>b</sup>	0.04
CL number			
Day 9	1.3 ± 0.05	1.2 ± 0.06	0.08
Day 16	1.3 ± 0.05	1.2 ± 0.06	0.09

<sup>1</sup> Ovulation was synchronized using Presynch + Ovsynch with or without 400 IU eCG on day 0.

<sup>2</sup> Cows with luteal regression after PGF<sub>2α</sub> administration on day 0 as determined visually (ultrasonography) or by change in serum progesterone concentrations.

<sup>3</sup> Cows ovulating a single follicle in response to the first GnRH injection of Ovsynch.

<sup>4</sup> Cows ovulating more than 1 follicle in response to first GnRH injection of Ovsynch.

<sup>5</sup> Cows ovulating a single follicle in response to the second GnRH injection of Ovsynch.

<sup>6</sup> Cows ovulating more than 1 follicle in response to second GnRH injection of Ovsynch.

**Table 2. Effect of equine chorionic gonadotropin (eCG) on pregnancy rates and pregnancy loss in lactating dairy cows**

Item	Treatment <sup>1</sup>		P-value
	eCG	Control	
Pregnancy rate per AI			
At 33 days, %	36.9	41.8	0.58
At 61 days, %	32.3	32.3	0.96
Pregnancy loss, %	4.6	9.1	0.34

<sup>1</sup> Ovulation was synchronized using Presynch + Ovsynch with or without 400 IU eCG on day 0.



REPRODUCTION

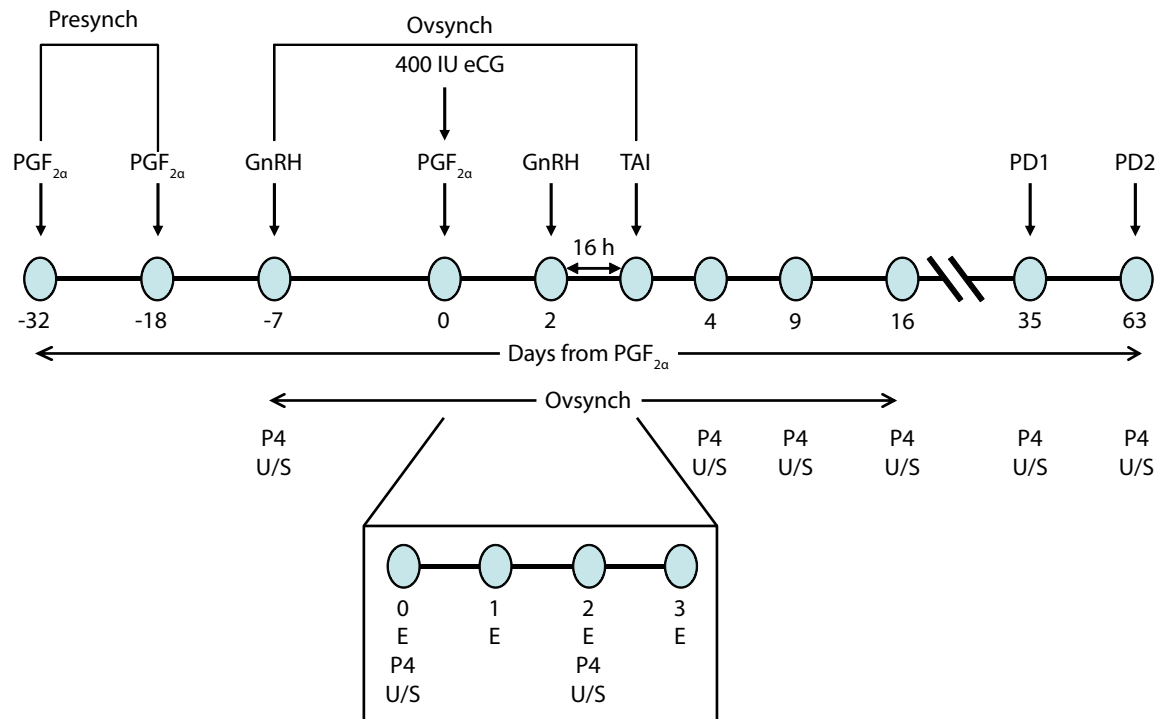

**Figure 1. Experimental design.**

Treatments for Presynch + Ovsynch timed artificial insemination (AI) protocol with or without administration of 400 IU equine chorionic gonadotropin (eCG) on day 0. PD = pregnancy diagnosis based on visualization of viable embryo; P4 = blood sampling and analysis of progesterone concentrations in circulating serum; E = blood sampling and analysis of estradiol concentrations in circulating serum; U/S = ultrasonography of the ovaries to assess size and changes in follicle and luteal structures.

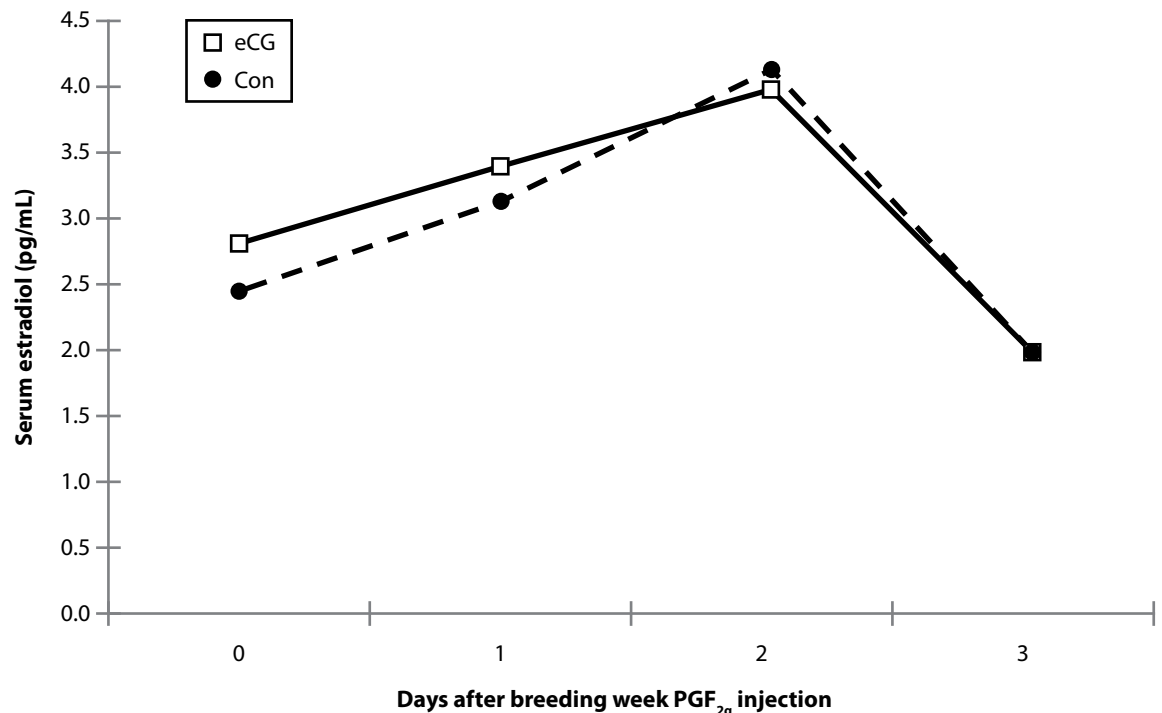

**Figure 2. Pattern of serum estradiol concentrations on days 0, 1, 2, and 3 of the study.**

## Acknowledgments

Appreciation is expressed to the following organizations for their support of dairy teaching, research, and extension at Kansas State University during 2009-2010.

Aerotech, Mason, MI  
AgTech, Inc., Manhattan, KS  
Arm & Hammer Animal Nutrition, Princeton, NJ  
Balchem Corporation, New Hampton, NY  
Cargill, Inc., Wayzata, MN  
Consolidated Container Company, Minneapolis, MN  
Danisco USA, New Century, KS  
Dekalb Asgrow, St. Louis, MO  
DeLaval, Kansas City, MO  
Elanco Animal Health, Greenfield, IN  
Fort Dodge Animal Health, Overland Park, KS  
Heart of America Dairy Herd Improvement Association, Manhattan, KS  
High Plains Dairy Management Conference  
Intervet/Schering-Plough Animal Health, Union, NJ  
Iowa Limestone, Des Moines, IA  
Kansas Agricultural Experiment Station, Manhattan, KS  
Kansas Dairy Commission, Wamego, KS  
Kansas Farm Management Association, Manhattan, KS  
Kansas Health and Environment, Topeka, KS  
Sweet Bran, Dalhart, TX  
Pfizer Animal Health, New York, NY  
Quality Liquid Feeds, Dodgeville, WI  
Rota-Mix, Dodge City, KS  
Select Sires, Plain City, OH  
USDA National Institute of Food and Agriculture, Washington, DC  
USDA National Needs Grant  
Western Dairy Management Conference  
Zinpro Corp., Eden Prairie, WI

Appreciation is expressed to Charlotte Bruna and Valerie Stillwell for typing the contents of this publication. The departments of Agricultural Economics and Biological and Agricultural Engineering at Kansas State University are recognized for their cooperation and contribution to our dairy research program.

## The Livestock and Meat Industry Council, Inc.

The Livestock and Meat Industry Council, Inc. (LMIC) is a nonprofit charitable organization supporting animal agriculture research, teaching, and education. This is accomplished through the support of individuals and businesses that make LMIC a part of their charitable giving.

Tax-deductible contributions can be made through gifts of cash, appreciated securities, real estate, life insurance, charitable remainder trusts, and bequests as well as many other forms of planned giving. LMIC can also receive gifts of livestock, machinery, or equipment. These types of gifts, known as gifts-in-kind, allow the donor to be eligible for a tax benefit based on the appraised value of the gift.

Since its inception in 1970, LMIC has provided student scholarships, research assistance, capital improvements, land, buildings, and equipment to support students, faculty, and the industry of animal agriculture. If you would like to be a part of this mission or would like additional information, please contact the Livestock and Meat Industry Council/Animal Sciences and Industry, Weber Hall, Manhattan, KS 66506 or call 785-532-1227.

### LMIC Board Members

Kyle Bauer	Bernie Hansen	Pat Koons
Jerry Bohn	Greg Henderson	Kelly Lechtenberg
Joe Downey	Patsy Houghton	Jan Lyons
Galen Fink	Steven Hunt	Gina Miller
Randy Fisher	Steve Irsik	Andrew Murphy
Mark Gardiner	Justin Janssen	Tom Perrier
Craig Good	Dan Johnson	Lee Reeve
Lyle Gray	Larry Jones	Ken Stielow
Sam Hands	Mark Knight	Warren Weibert

### Royal Board Members

Dell Allen	Henry Gardiner	Don Smith
Richard Chase	Don Good	Duane Walker
Calvin Drake	Kenny Knight	
Stan Fansher	Harland Priddle	



# DAIRY RESEARCH 2010

Copyright 2010 Kansas State University Agricultural Experiment Station and Cooperative Extension Service. Contents of this publication may be freely reproduced for educational purposes. All other rights reserved. In each case, give credit to the author(s), Dairy Research 2010, Kansas State University, December 2010. Contribution no. 11-129-S from the Kansas Agricultural Experiment Station.

Brand names appearing in this publication are for product identification purposes only. No endorsement is intended, nor is criticism implied of similar products not mentioned.

Publications from Kansas State University are available on the World Wide Web at: [www.ksre.ksu.edu](http://www.ksre.ksu.edu)

KANSAS STATE UNIVERSITY AGRICULTURAL EXPERIMENT STATION  
AND COOPERATIVE EXTENSION SERVICE