

January 2015

## Using Estrus-Detection Patches to Vary Time of Insemination Improves Pregnancy Rates Compared with One Single Timed Insemination

S. L. Hill

*Kansas State University*, scotth22@ksu.edu

D. M. Grieger

*Kansas State University*, dgrieger@ksu.edu

K C. Olson

*Kansas State University*, kcolson@ksu.edu

J. R. Jaeger

*Kansas State University*, jrjaeger@ksu.edu

*See next page for additional authors*

Follow this and additional works at: <https://newprairiepress.org/kaesrr>

 Part of the [Agriculture Commons](#), and the [Animal Sciences Commons](#)

### Recommended Citation

Hill, S. L.; Grieger, D. M.; Olson, K C.; Jaeger, J. R.; and Stevenson, J. S. (2015) "Using Estrus-Detection Patches to Vary Time of Insemination Improves Pregnancy Rates Compared with One Single Timed Insemination," *Kansas Agricultural Experiment Station Research Reports*: Vol. 1: Iss. 1. <https://doi.org/10.4148/2378-5977.1025>

This report is brought to you for free and open access by New Prairie Press. It has been accepted for inclusion in Kansas Agricultural Experiment Station Research Reports by an authorized administrator of New Prairie Press. Copyright January 2015 Kansas State University Agricultural Experiment Station and Cooperative Extension Service. Contents of this publication may be freely reproduced for educational purposes. All other rights reserved. Brand names appearing in this publication are for product identification purposes only. No endorsement is intended, nor is criticism implied of similar products not mentioned. K-State Research and Extension is an equal opportunity provider and employer.



---

# Using Estrus-Detection Patches to Vary Time of Insemination Improves Pregnancy Rates Compared with One Single Timed Insemination

## Abstract

Timed artificial insemination (TAI) of beef cows at a predetermined time is a management tool that reduces labor costs associated with conventional heat detection before insemination. Multiple research trials have examined timing of the individual components of the developed protocols associated with TAI. The 7-day CO-Synch + progesterone insert (controlled internal drug release; CIDR) protocol has been shown to initiate ovulation effectively in cycling and noncycling suckled beef cows, often producing pregnancy rates greater than 50% in beef cows. In the current research, we examined using two targeted insemination intervals depending on the occurrence of estrus. We hypothesized that by more closely synchronizing estrus and insemination that pregnancy rates would be increased. We further hypothesized that cows that do not demonstrate estrus and are subjected to a TAI protocol might benefit from an increased interval to insemination.

## Keywords

artificial insemination, timed insemination, heat detection, estrus

## Creative Commons License



This work is licensed under a [Creative Commons Attribution 4.0 License](https://creativecommons.org/licenses/by/4.0/).

## Authors

S. L. Hill, D. M. Grieger, K C. Olson, J. R. Jaeger, and J. S. Stevenson

## Using Estrus-Detection Patches to Vary Time of Insemination Improves Pregnancy Rates Compared with One Single Timed Insemination

*S.L. Hill, D.M. Grieger, KC Olson, J.R. Jaeger, and J.S. Stevenson*

### Introduction

Timed artificial insemination (TAI) of beef cows at a predetermined time is a management tool that reduces labor costs associated with conventional heat detection before insemination. Multiple research trials have examined timing of the individual components of the developed protocols associated with TAI. The 7-day CO-Synch + progesterone insert (controlled internal drug release; CIDR) protocol has been shown to initiate ovulation effectively in cycling and noncycling suckled beef cows, often producing pregnancy rates greater than 50% in beef cows. In the current research, we examined using two targeted insemination intervals depending on the occurrence of estrus. We hypothesized that by more closely synchronizing estrus and insemination that pregnancy rates would be increased. We further hypothesized that cows that do not demonstrate estrus and are subjected to a TAI protocol might benefit from an increased interval to insemination.

### Experimental Procedures

A total of 186 primiparous and 1,133 multiparous cows in 10 locations across 6 states were included in this analysis (Table 1). All cows were subjected to a 7-day CO-Synch + CIDR TAI procedure (Figure 1). This procedure was initiated with 100  $\mu$ g gonadotropin-releasing hormone (GnRH; 2 mL Factrel; Pfizer Animal Health, Whitehouse Station, NJ) and a simultaneous intravaginal insertion of a new CIDR insert (Pfizer Animal Health) containing 1.38 g progesterone, followed in 7 days by CIDR insert removal and a concurrent intramuscular injection of 25 mg prostaglandin  $F_{2\alpha}$  (PGF; 5 mL Lutalyse; Pfizer Animal Health). An estrus-detection patch (Estroject, Rockway Inc., Spring Valley, WI) was applied immediately cranial from the tail head at the highest point of the rump at the time of CIDR insert removal.

Estrus-detection patches were interpreted at 60 hours post application (Figure 1). Patches that were more than 50% colored or missing with evidence of other estrus activity (ruffled tail-head hair, mucus, or rubbed off hair on back or pin bones) were classified as activated. All cows with activated patches (Early Estrus) at 60 hours were inseminated and administered a GnRH injection. Remaining cows were allocated

randomly to 3 treatments (Figure 2): (1) received GnRH injection and AI at 60 hours (Early GnRH-Early AI), (2) received a GnRH injection at 60 hours and AI at 75 hours (Early GnRH-Delayed AI), or (3) received a GnRH injection and AI at 75 hours (Delayed GnRH-Delayed AI). Non-activated patches at 60 hours were re-examined at 75 hours and results were recorded.

Body condition scores (BCS; 1 = thin; 9 = very fat) were assigned 10 days before the initial GnRH injection. Blood samples were collected via caudal vessel puncture 10 days before and at the initial GnRH injection and CIDR insertion. Blood samples were assayed for progesterone by radioimmunoassay. Cycling status of cows was classified based on serum progesterone concentration. Cows were defined to be cycling when progesterone concentration was  $\geq 1$  ng/mL in either or both samples or noncycling when progesterone was  $< 1$  ng/mL in both samples. Days postpartum were calculated as the number of days from calving until the day of TAI.

Cows were either exposed to cleanup bulls beginning 10 to 12 days after TAI or re-inseminated at subsequent estrus. At 35 days after AI, pregnancy was confirmed by transrectal ultrasonography (Aloka 500V, 5 MHz transrectal transducer, Wallingford, CT). A positive pregnancy outcome required the presence of a corpus luteum and uterine fluid or uterine fluid and an embryo with a heartbeat. A final pregnancy diagnosis was determined at least 35 days after the end of the breeding season via transrectal ultrasonography or palpation per rectum.

## Results and Discussion

Cows identified as having activated patches by either 60 or 75 hours were more ( $P < 0.001$ ) likely to become pregnant to AI than those with unmarked patches (67.5 vs 43.1%). The Early Estrus cows had the greatest ( $P < 0.05$ ) risk of pregnancy (64.8%) compared with other treatments (Figure 3). The cows in 2 treatments (Early GnRH-Delayed AI and Delayed GnRH-Delayed AI) inseminated at 75 hours had greater ( $P < 0.05$ ) risk of pregnancy to AI than the Early GnRH-Early AI treatment (55.1 and 51.9 vs 43.1%, respectively). Cows that did not initially show estrus by 60 hours but had activated patches by 75 hours were more ( $P < 0.05$ ) likely to become pregnant than their nonestrus herd mates when they were in the Delayed GnRH-Delayed AI (69.3 vs 35.8%;  $P < 0.05$ ) or Early GnRH-Delayed AI (70.5 vs 46.3%;  $P < 0.05$ ) treatments, but not in the Early GnRH-Early AI (49.6 vs 39.5%) treatment (Figure 4).

Pregnancy rate per AI was greater ( $P < 0.001$ ) in cows that calved more than 79 days before AI (56.8 vs. 47.8%) compared with later-calving cows ( $< 78$  days from calving to AI). No differences in pregnancy rate to AI were detected between primiparous and multiparous cows. Likewise, cows with a BCS  $< 5$  had pregnancy rates that did not differ from their fatter herdmates.

Use of estrus-detection patches enables management of reproductive groups of cows that are more likely to conceive to AI. Regardless of the prior cycling status of cows, cows are more likely to become pregnant to AI if they demonstrate estrus. By delaying insemination in cows to 75 hours for those that have not expressed estrus by 60 hours, delayed-estrus cows have an additional opportunity to show heat. In this experiment,

51.4% of cows that did not initially show heat by 60 hours, in fact, demonstrated estrus between 60 and 75 hours. Two insemination times 15 hours apart should increase the number of cows that become pregnant to AI.

## Implications

Use of estrus-detection patches coupled with split timing of insemination are management tools that will enable cattlemen to improve the efficiency of TAI procedures with minimal investment in supplies and labor.

**Table 1. Characteristics of suckled cows (experimental units)**

Location	No. cows	Body condition score	Days postpartum at artificial insemination	Parity	Cycling status <sup>1</sup>
					%
CSU	93	5.8 ± 0.7	73.7 ± 16.5	4.1 ± 2.8	*
Hays	179	5.7 ± 0.5	92.9 ± 14.4	4.0 ± 2.4	96
Hog (Konza)	18	6.4 ± 0.6	73.8 ± 16.7	5.7 ± 2.1	44
NDSU	174	5.4 ± 0.6	70.9 ± 11.8	3.8 ± 2.7	*
North Konza	57	6.9 ± 0.8	67.4 ± 21.6	2.3 ± 0.5	74
PBU	65	4.8 ± 0.5	75.1 ± 13.7	4.6 ± 2.3	66
PBURFI	51	4.5 ± 0.4	65.1 ± 15.3	4.3 ± 2.6	59
SDSU CCU	102	5.6 ± 0.4	81.5 ± 15.3	3.3 ± 2.6	32
South Konza	29	6.8 ± 0.6	60.6 ± 22.5	2.2 ± 0.4	59
UM	125	4.9 ± 0.7	69.8 ± 25.8	2.5 ± 0.7	61
VA-Aug	214	4.5 ± 0.9	78.6 ± 20.2	4.9 ± 3.3	63
VA-Bland	218	4.2 ± 0.6	75.2 ± 17.8	4.8 ± 3.1	52
Total	1,325	5.4	73.7	3.9	61

<sup>1</sup>Cycling determined by serum progesterone concentration before CO-Synch + CIDR program was initiated.

\*Locations with no blood collection.

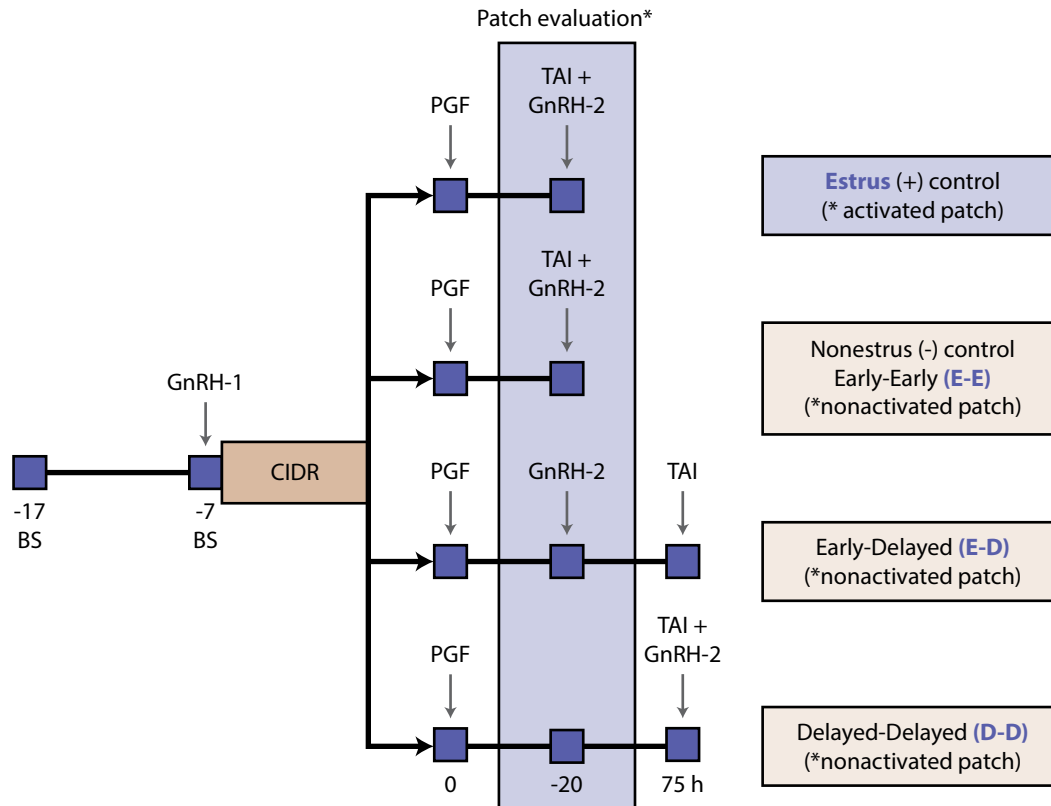

**Figure 1. Experimental treatments and procedures.**

BS = blood sample; CIDR = progesterone insert; GnRH = gonadotropin-releasing hormone; PGF = prostaglandin F<sub>2α</sub>; TAI = timed artificial insemination.



**Figure 2. Examples of activated and nonactivated patches (Estroprotect, Rockway Inc., Spring Valley, WI).**

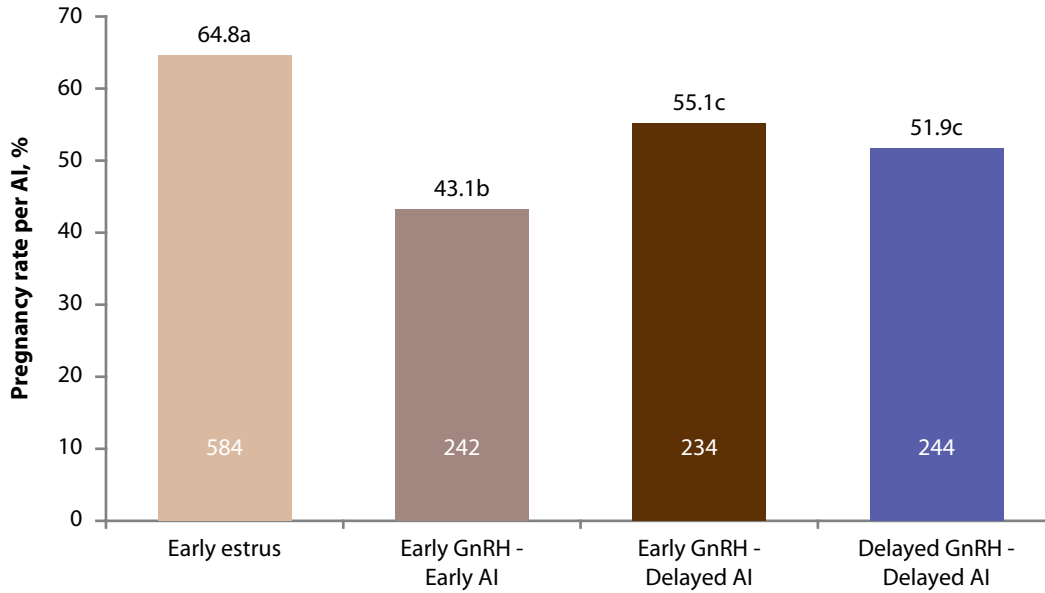

Figure 3. Pregnancy rates per AI. Numbers within bars reflect number of cows per treatment. Treatment mean percentages with uncommon letters differ ( $P < 0.05$ ).

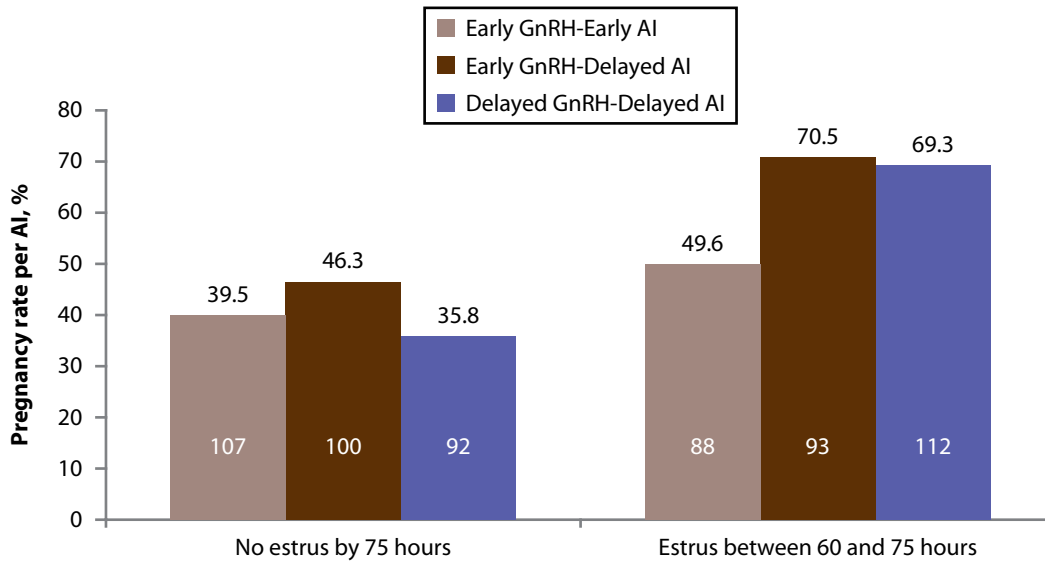

Figure 4. Pregnancy rates per AI of cows not showing estrus by 75 hours compared with those cows showing estrus between 60 and 75 hours. Numbers within bars reflect number of cows per treatment.