

2006

Resynchronization of ovulation and conception in nonpregnant dairy cows and heifers

M.A. Portaluppi

D.E. Tenhouse

Jeffrey S. Stevenson

Follow this and additional works at: <https://newprairiepress.org/kaesrr>



Part of the [Dairy Science Commons](#)

Recommended Citation

Portaluppi, M.A.; Tenhouse, D.E.; and Stevenson, Jeffrey S. (2006) "Resynchronization of ovulation and conception in nonpregnant dairy cows and heifers," *Kansas Agricultural Experiment Station Research Reports*: Vol. 0: Iss. 2. <https://doi.org/10.4148/2378-5977.3153>

This report is brought to you for free and open access by New Prairie Press. It has been accepted for inclusion in Kansas Agricultural Experiment Station Research Reports by an authorized administrator of New Prairie Press. Copyright 2006 Kansas State University Agricultural Experiment Station and Cooperative Extension Service. Contents of this publication may be freely reproduced for educational purposes. All other rights reserved. Brand names appearing in this publication are for product identification purposes only. No endorsement is intended, nor is criticism implied of similar products not mentioned. K-State Research and Extension is an equal opportunity provider and employer.



Resynchronization of ovulation and conception in nonpregnant dairy cows and heifers

Abstract

Our objectives were to determine various factors influencing upfront single and multiple ovulation in response to GnRH in a timed artificial insemination (TAI) protocol and subsequent fertility after altering timing of the second GnRH injection and AI relative to PGF2 α injection. Replacement heifers (n = 86) and 613 lactating cows previously inseminated were diagnosed not pregnant at biweekly intervals to form 77 breeding clusters spanning 36 months. At not-pregnant diagnosis (day 0), females received 100 μ g of GnRH, and they received 25 mg of PGF2 α 7 days later. Females in 2 treatments received GnRH 48 hr (G48) after PGF2 α injection and TAI at the time of the second GnRH injection (G48 + TAI48) or 24 hr later (G48 + TAI72). Females in the third treatment received GnRH 72 hr after PGF2 α , when inseminated (G72 + TAI72). Ovaries of females in 65 clusters were scanned at day 0 (first GnRH injection) and 7 days later (PGF2 α injection). Ovarian structures were mapped, and ovulation in response to the first GnRH injection was detected on day 7. When estrus was detected before scheduled TAI, females were inseminated; otherwise TAI conception of remaining females was based on timing of GnRH and AI in 3 treatments. On day 7, 1 or more luteal structures (CL) were detected in 46% of females. Conception rate was 26.5% (98/701) in females that showed estrus and were inseminated early. Pregnancy rate was greater in females that ovulated after the first GnRH injection (day 0) and during nonsummer months. Compared with females in late diestrus at nonpregnant diagnosis, cows in early diestrus or those with functional cysts had greater pregnancy rates, but rates were not different from those of cows in proestrus or in metestrus or anestrus. Pregnancy rates did not differ among treatments, but a tendency was detected for a treatment x lactation number interaction. In heifers and first-lactation cows, the G72 + TAI72 treatment produced fewer pregnancies, whereas G48 + TAI48 treatment was least efficacious in older cows. In a TAI protocol for previously inseminated dairy females that are diagnosed not pregnant, subsequent timed AI pregnancy rates are greater when females are in early diestrus, ovulate in response to the first GnRH injection, or both. (Key Words: Luteolysis, Ovsynch, Ovulation,; Dairy Day, 2006, Kansas State University, Manhattan, KS, 2006;

Keywords

Diary Day, 2006; Kansas Agricultural Experiment Station contribution; no. 07-118-S; Report of progress (Kansas State University. Agricultural Experiment Station and Cooperative Extension Service); 965; Dairy; Luteolysis; Ovsynch; Ovulation; Pregnancy rate

Creative Commons License



This work is licensed under a [Creative Commons Attribution 4.0 License](https://creativecommons.org/licenses/by/4.0/).

RESYNCHRONIZATION OF OVULATION AND CONCEPTION IN NONPREGNANT DAIRY COWS AND HEIFERS

J. S. Stevenson, M A. Portaluppi, and D. E. Tenhouse

Summary

Our objectives were to determine various factors influencing upfront single and multiple ovulation in response to GnRH in a timed artificial insemination (TAI) protocol and subsequent fertility after altering timing of the second GnRH injection and AI relative to PGF_{2α} injection. Replacement heifers (n = 86) and 613 lactating cows previously inseminated were diagnosed not pregnant at biweekly intervals to form 77 breeding clusters spanning 36 months. At not-pregnant diagnosis (day 0), females received 100 µg of GnRH, and they received 25 mg of PGF_{2α} 7 days later. Females in 2 treatments received GnRH 48 hr (G48) after PGF_{2α} injection and TAI at the time of the second GnRH injection (G48 + TAI48) or 24 hr later (G48 + TAI72). Females in the third treatment received GnRH 72 hr after PGF_{2α}, when inseminated (G72 + TAI72). Ovaries of females in 65 clusters were scanned at day 0 (first GnRH injection) and 7 days later (PGF_{2α} injection). Ovarian structures were mapped, and ovulation in response to the first GnRH injection was detected on day 7. When estrus was detected before scheduled TAI, females were inseminated; otherwise TAI conception of remaining females was based on timing of GnRH and AI in 3 treatments. On day 7, 1 or more luteal structures (CL) were detected in 46% of females. Conception rate was 26.5% (98/701) in females that showed estrus and were inseminated early. Pregnancy rate was greater in females that ovulated after the first GnRH injection (day 0) and during nonsummer months. Compared with females in late diestrus at

nonpregnant diagnosis, cows in early diestrus or those with functional cysts had greater pregnancy rates, but rates were not different from those of cows in proestrus or in metestrus or anestrus. Pregnancy rates did not differ among treatments, but a tendency was detected for a treatment × lactation number interaction. In heifers and first-lactation cows, the G72 + TAI72 treatment produced fewer pregnancies, whereas G48 + TAI48 treatment was least efficacious in older cows. In a TAI protocol for previously inseminated dairy females that are diagnosed not pregnant, subsequent timed AI pregnancy rates are greater when females are in early diestrus, ovulate in response to the first GnRH injection, or both.

(Key Words: Luteolysis, Ovsynch, Ovulation, Pregnancy Rate.)

Introduction

Several factors are known to influence fertility after a timed AI (TAI) in dairy cattle when ovulation is synchronized with a GnRH injection followed in 7 days by PGF_{2α} in an Ovsynch-like protocol (GnRH injection given 7 days before and 48 hr after luteolysis is induced by PGF_{2α}). Day of the estrous cycle at the onset of such protocols influenced incidence of ovulation and follicle diameter after the first leading GnRH injection and the second ovulatory GnRH injection that followed PGF_{2α}-induced luteolysis. Cows treated between days 1 and 4 had the smallest incidence of ovulation (23%), followed by those between days 10 and 16 (54%), days 17 to 21 (77%), and days 5 to 9 (96%). Further, diame-

ter of the ovarian follicle that ovulated in response to the first GnRH injection was smaller for cows on days 1 to 4 and 17 to 21 than on days 5 to 16. Cows early (d 1 to 4) and late (days 17 to 21) in the estrous cycle at the first GnRH injection had larger-diameter ovulatory follicles than those injected on days 5 to 13, whereas pregnancy rates were greatest for cows in which the Ovsynch protocol was initiated between days 5 and 14 (42%) and less for those injected on days 1 to 4 and 14 to 21 (32%). Thus, follicle size at the onset of the Ovsynch protocol seems to be important to predispose a maximum ovulatory response to GnRH. Little is known about ovulatory responses to GnRH differing based on ovarian follicular populations, luteal status, season, and lactation status.

Timing of the GnRH and AI influence TAI pregnancy rates. When GnRH was administered at 48 hr after the PGF_{2α} injection of the Ovsynch protocol, and cows were inseminated at 48, 56, 64, 72, or 80 hr after PGF_{2α}, pregnancy rates at first service were maximal at 64 hr or 16 hr after GnRH. In lactating dairy cows inseminated after 2 presynchronizing injections of PGF_{2α} given 14 days apart (Presynch) and initiating the Ovsynch protocol 12 days after the second Presynch injection, various times of GnRH and TAI were tested. Those cows given GnRH at 48 hr after the PGF_{2α} injection of Ovsynch and inseminated at that time (48 hr after PGF_{2α}) or 24 hr later (Cosynch 48) had lesser pregnancy rates than those of cows injected and inseminated at 72 hr after PGF_{2α} (Cosynch 72).

The obvious advantage of such treatments is the convenience of carrying out all hormonal injections and TAI at the same time of the day, when cows are conveniently restrained by feed-line lockups. In recent studies, similar treatments initiated 11 days after Presynch (Cosynch 48 and Cosynch 72) produced lesser pregnancy rates in dairy cows, compared with

administering GnRH at 56 hr after PGF_{2α} and inseminating cows 16 hr later. These results also were consistent in that study for cows in which the Ovsynch protocol was applied with the same treatments after a not-pregnant diagnosis.

The objective of our study was to examine various factors that influence the leading, first GnRH-induced ovulatory response and resulting pregnancy rates in conjunction with altered timing of the second GnRH injection and TAI.

Procedures

Dairy females (replacement heifers and lactating cows) previously inseminated were diagnosed nonpregnant at biweekly intervals. At the nonpregnant diagnosis, females were blocked by lactation number (0, 1, or 2+) and assigned randomly to 3 treatments consisting of variations of the Ovsynch protocol (Figure 1). Cows in 2 treatments received injections of GnRH 7 d before, and 48 hr (G48) after the PGF_{2α} injection. Timed AI was conducted at the time of the second GnRH injection (G48 + TAI48) or 24 hr later (G48 + TAI72). Cows in the third treatment received the injections of GnRH 7 days before, and at 72 hr after PGF_{2α}, and were inseminated at the time of the second GnRH injection (G72 + TAI72). When estrus was detected before projected TAI, females were inseminated, based on symptoms of estrus, according to the a.m.-p.m. rule.

Ultrasonography was conducted to monitor ovarian structures in the first 65 of the 77 clusters of females assigned to treatments (584 of 699 females). Ovarian follicles were mapped and sized (all follicles ≥ 5 mm were measured) on day 0. Numbers of follicles and luteal structures were quantified per ovary. On day 7, occurrence of ovulation of any follicle was recorded in response to the first GnRH injection given on day 0.

Results and Discussion

Incidence of ovulation in response to the first GnRH injection averaged 46%. It tended ($P = 0.07$) to differ in magnitude among different days of the estrous cycle (range = 36.5 to 58.3%). Replacement heifers had the smallest incidence of ovulation (29.2%). As lactation number increased from 0 to 3 or more, ovulation incidence increased ($P < 0.001$) linearly.

Timed AI pregnancy rates among females that were scanned, regardless of whether they ovulated in response to GnRH, was not influenced by treatment, days of the estrous cycle, luteal status, lactation number, or number of CL at the time of the first GnRH injection (not shown). Pattern of pregnancy rates over days of the estrous cycle was fitted to a fifth-order polynomial curve ($P < 0.05$), and tended to parallel the pattern of ovulation incidence (not shown).

Pregnancy rate tended ($P = 0.075$) to decrease linearly as the number of follicles ≥ 8 mm in diameter increased. Females that ovulated in response to the first GnRH injection had subsequently greater ($P < 0.05$) pregnancy rates than those of females that did not ovulate (32.1 vs. 20.2%). When incidence of ovulation was replaced by the number of ovulations (0, 1, 2 or more), pregnancy rates were 20.0% ($n = 276$), 31.0% ($n = 176$), and 38.5% ($n = 32$), respectively. No difference in pregnancy rate was detected among those females that ovulated 1 vs. 2 or more follicles before timed AI.

Pregnancy rates in females that were diagnosed as cystic (39.3%; $n = 17$) and in early diestrus (28.7%; $n = 264$) were greater ($P < 0.05$) than in females in late diestrus (11.5;

$n = 78$), whereas fertility in anestrus females (19.5%; $n = 16$) and those in proestrus or metestrus (23.5%; $n = 152$) did not differ from either of the preceding cycling status categories. As expected, pregnancy rates were reduced ($P < 0.05$) during summer, compared with other seasons.

Pregnancy rates in dairy females that ovulated were affected by the total number of follicles ≥ 8 mm in diameter and by season. As number of total follicles decreased, pregnancy rates decreased ($P < 0.001$) linearly. Pregnancy rates also were reduced ($P < 0.05$) during summer for cows that ovulated.

Pregnancy rates did not differ among treatments, but a strong tendency ($P = 0.09$) was detected for an interaction between treatment and lactation number (Figure 2). In heifers and first-lactation cows, the G72 + TAI72 produced fewer pregnancies, whereas the G48 + TAI48 was least efficacious in older (3+) cows. Females initiating the Ovsynch protocol in early diestrus (22.8%; $n = 336$), proestrus or metestrus (22.5%; $n = 207$), or having a cystic functional structure (27.4%; $n = 17$) had greater ($P < 0.05$) pregnancy rates than those of anestrus females (5.7%; $n = 22$) or those in late diestrus (8.6%; $n = 103$).

In summary, in heifers and first-lactation cows, the G72 + TAI72 treatment produced fewer pregnancies, whereas G48 + TAI48 treatment was least efficacious in older cows. In a TAI protocol for previously inseminated dairy females that are diagnosed not pregnant, subsequent timed AI pregnancy rates are greater when females are in early diestrus or ovulate in response to the first GnRH injection.

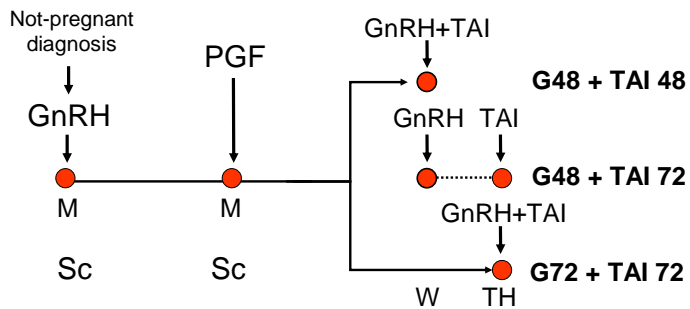

Figure 1. Experimental Design of Treatments. Nonpregnant heifers and lactating cows were injected with GnRH upon not-pregnant diagnosis and then 7 d later were injected with PGF_{2α}. Cows were injected with GnRH at 48 h after PGF_{2α} (G48) and inseminated at 48 (TAI48) or 72 h (TAI72) after PGF_{2α} or injected with GnRH at 72 h (G72) at the same time as timed AI (TAI72). M = Monday, W = Wednesday, TH = Thursday, SC = ovarian scans by transrectal ultrasonography, GnRH or G = gonadotropin-releasing hormone, PGF = PGF_{2α}, and TAI = timed AI.

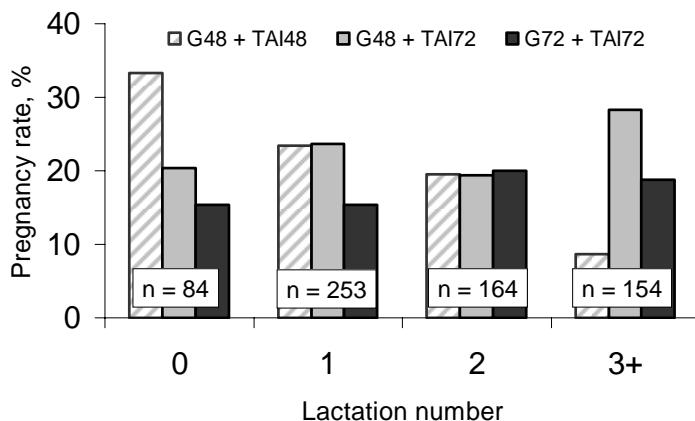

Figure 2. Interaction of Treatment × Lactation Number for Timed AI (TAI) Pregnancy Rate in Dairy cattle. Depending on the model, the interaction *P* values varied between 0.09 and 0.12. Nonpregnant females were injected with GnRH upon not-pregnant diagnosis and then 7 d later were injected with PGF_{2α}. Cows were injected with GnRH at 48 h after PGF_{2α} (G48) and inseminated at 48 (TAI48) or 72 h (TAI72) after PGF_{2α} or injected with GnRH at 72 h (G72) at the same time as timed AI (TAI72).